



TS 98 XEA



Our commitment for a sustainable future

Acting in an environmentally responsible manner is one of our maxims. We are committed to sustainable development as one of our business maxims. DORMA's aim is to ensure energy-saving and resource-conserving production, a high recycling ratio and the longevity of our quality products. At the product level, the environmental product declaration (EPD), based on holistic life cycle assessments, is used to calculate the sustainability of buildings. The full EPD is available at www.dormakaba.com.

Table of contents

06	Customer Confection	26	Smoke detector
08	Functions	28	Accessories
		28	1-leaf doors
10	Data and features	29	2-leaf doors
12	Slide channels for 1-leaf doors	30	Scope of delivery and accessories
12	G-N XEA	30	1-leaf doors
14	G-EMF XEA	32	2-leaf doors
16	G-EMR XEA		
18	Slide channels for 2-leaf doors	34	Specification texts
18	GSR XEA	34	1-leaf doors
19	GSR-EMF XEA	35	Smoke detectors
20	GSR-EMR XEA	36	2-leaf doors
22	GSR XEA BG		
23	GSR-EMF 2 XEA BG		
24	GSR-EMR XEA BG	38	Regulations and information
		38	Hold-open devices

01



02



03



04



01
TS 98 XEA
 Door leaf installation, pull side

02
TS 98 XEA EMF with RMZ XEA
 with electromechanical hold-open unit
 and smoke detector in XEA design,
 pull side installation

03
TS 98 XEA EMR
 with electromechanical hold-open unit
 and integrated smoke detector,
 pull side installation

04
TS 98 XEA GSR EMF
 Door coordinator with
 electromechanical hold-open unit,
 pull side installation

High-quality architectural solutions demand components that are also high quality. Door closers and hold-open devices in aesthetic XEA design allow for a customizable appearance. By focusing on only one single door closer for all installation types, the number of product variants and complexity along the entire value chain is reduced.

XEA – Excellent form in many colors.

Combine color variants and surfaces as desired – in line with the entire installation

The new creative leeway in the XEA design means customer confection. A multitude of color combinations for decor plates, cover, slide channels, and main arms are available for selection.

A selected range of material impressions and surface quality meets the requirements of demanding interior architects in many ways.

- Excellent visual integration of the door closer
- Flexible adaptation to the door design
- Easy ordering process



1



2



3



4



5



6

01
Silver similar to RAL 9006 (P 600)

03
Stainless steel design (P 700)

05
Gold (P 750)

02
White similar to RAL 9016 (P 100)

04
White similar to RAL 9010 (P 210)

06
Black similar to RAL 9005 (P 190)



07
TS 98 XEA White similar to RAL 9016 (P 100)
G-N XEA stainless steel design (P 700)

09
TS 98 XEA Stainless steel design (P 700)
G-N XEA Silver similar to RAL 9006 (P 600)

08
TS 98 XEA Gold (P 750)
G-N XEA Gold (P 750)

10
TS 98 XEA Black similar to RAL 9005 (P 190)
G-N XEA White similar to RAL 9016 (P 100)

EN 1 to EN 6, pull or push side? One door closer for all applications!

For high-quality architectural solutions in the project

The centerpiece of the TS 98 XEA slide channel door closer system is the heart-shaped cam. Together with the innovative, hydraulic functions, the TS 98 XEA system's unique Cam Action Technology makes it very comfortable to pass through the door.

The door closer system in XEA design impresses due to

- One door closer for all installation types
- Three different closing ranges
- Standard delayed closing
- Standard backcheck
- Conveniently adjust all settings from the front
- Door width up to 1,400 mm
- Usable at up to -40°C

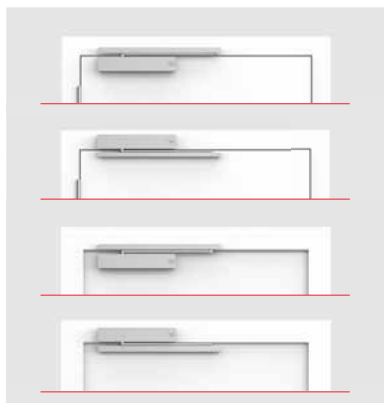

A door closer for all installation types

The TS 98 XEA can be installed on the pull or push side, on the transom or the door leaf and on the left-hand or right-hand side.



Closes at 180°

If the door closer is mounted on the pull side, 180° closing is possible with both door leaf and transom installation.



Rapidly decreasing opening torque

The resistance that needs to be overcome when opening the door instantly decreases. Children and the elderly in particular will appreciate so much comfort.

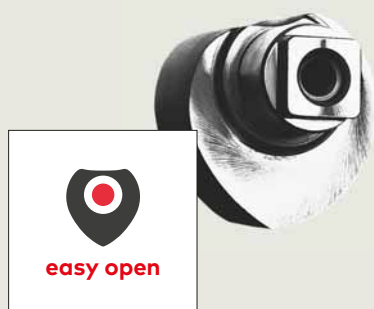

Torque curve TS 98 XEA (Closing force adjustment EN 6)

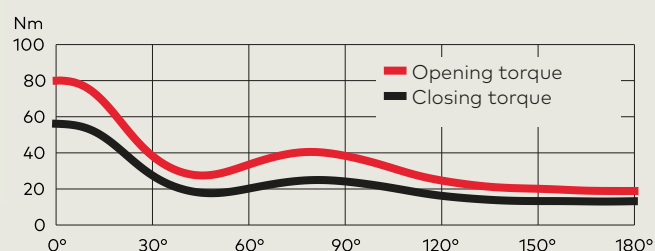



SoftFlow – Silent closing

A combination of two adjustable closing ranges (15°–0° and 7°–0°) allows for the door to close silently.



Delayed closing – DC/SV

The delayed closing reduces the closing speed until the door closing angle reaches 70°. As a result, there is always enough time to pass through the door.

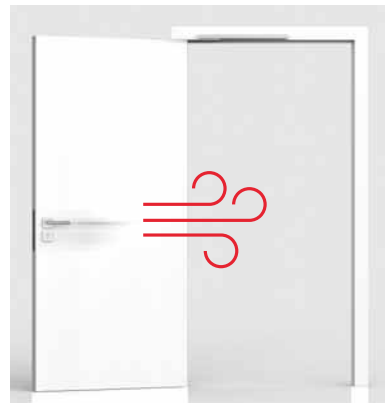

Backcheck– BC/OD

Thanks to the backcheck function, the momentum of a flung-open door or a door caught by the wind is mostly cushioned. This protects the wall and door from damage. However, we still recommend using a door stop.

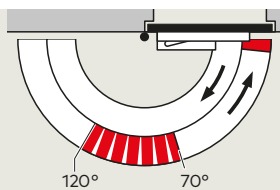

Adjustable delayed closing

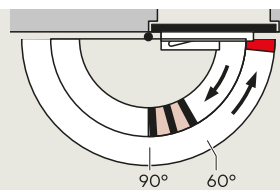

Adjustable backcheck

Flexible technology

Can be universally used for one and two-leaf door applications

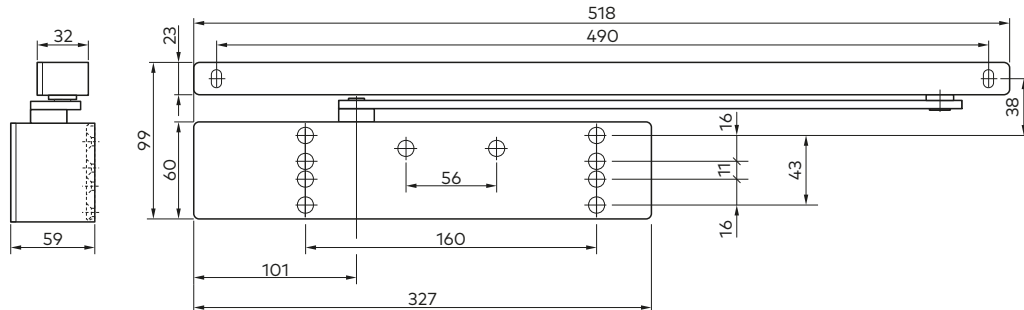

Whether it is one-leaf or two-leaf, DIN left or right – the TS 98 XEA is dormakaba's single door closer for all installation types. As a result, the number of product variants and complexity in installation is reduced while simultaneously increasing flexibility at the construction site.

The mounting plate with a universal hole pattern system offers the optimum or required fastening for many different door constructions. Adjustments are easily made from the front.

Data and features		TS 98 XEA
Variable closing force	Size	EN 1-6
Standard doors ¹⁾	≤ 1400 mm	●
External doors, outward opening ¹⁾	≤ 1400 mm	●
For fire and smoke control doors ¹⁾	≤ 1400 mm	●
Same design for DIN-L and DIN-R		●
Same design for pull and push side		●
Arm assembly type	Standard	–
	Slide channel	●
Closing force can be adjusted from the front with the adjusting screw		●
Visual closing force indicator		●
Closing speed adjustable by valve		●
SoftFlow: second closing range, 15°–0° and adjustable via valve		●
Latching speed adjustable via valve		●
Backcheck (BC/OD), adjustable via valve		●
Delayed closing (DC/SV) adjustable via valve		●
Hold-open		○
Weight in kg		4.5
Dimensions in mm	Length (L)	327
	Depth (W)	59
	Height (H)	60
Door closer tested according to EN 1154 Certificate number 0432-CPR-00026-90		●
Hold-open devices tested according to EN 1155		●
Door coordinator tested according to EN 1158		●
Smoke detection (integrated or external) tested according to EN 14637		●
CE-mark for building products		●
Barrier-free according to DIN 18040 for door widths (mm) up to a max of		1250
Environmental product declaration according to ISO 14025 Program owner: Institut Bauen und Umwelt e.V. Declaration number: EPD-ARG-20160183-IBG1-DE		●
Temperature range up to -40°C		●

● Yes – No ○ Option

¹⁾ For exceptionally tall and heavy doors and doors that constantly close against strong wind pressure, we recommend selecting the next-biggest door closer size or setting a stronger closing force.

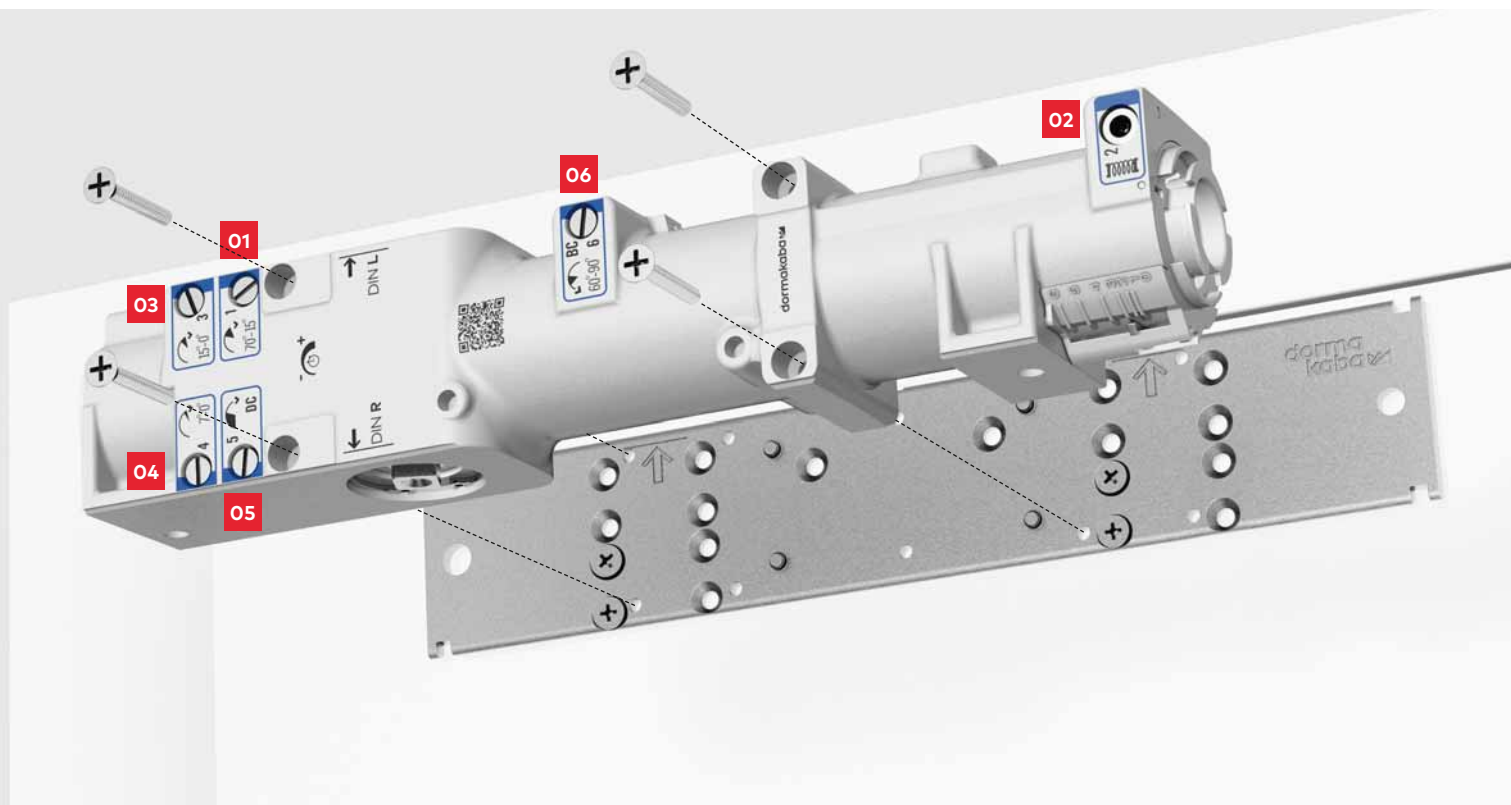

All functions are adjustable from the front

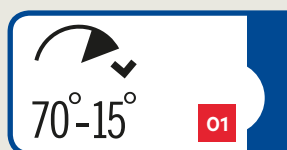

- 1 Adjustable closing speed between 70° and 15°.



- 2 Closing force adjustment EN1-6
A visual display (closing force indicator) shows the selected closing force. Easy to adjust from the front using a cordless screwdriver.

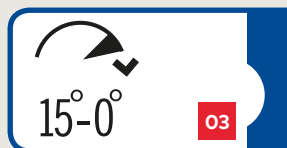

- 3 SoftFlow: adjustable closing range from 15° to 0° – allows for the door to close silently.

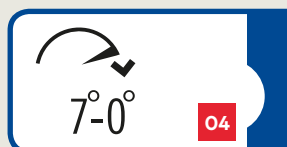

- 4 Adjustable latching speed in the 7°-0° closing range.



- 5 Delayed closing – DC/SV Closing speed reduced to 70°. Allows for sufficient time to go through the door with luggage, baby carriages, hospital beds, etc.



- 6 Backcheck – Thanks to the backcheck function, the momentum of a flung-open door or a door caught by the wind is mostly cushioned. This protects the wall and door from damage. However, we still recommend using a door stop.

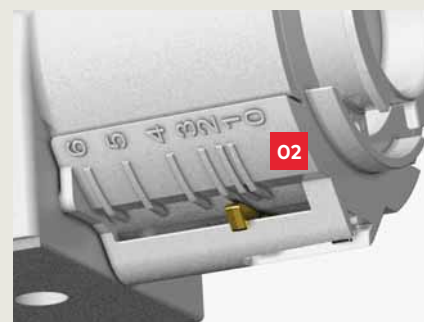

Indicator according to size information in EN 1154 regarding door width.

G-N XEA Slide channel

Standard design for 1-leaf doors

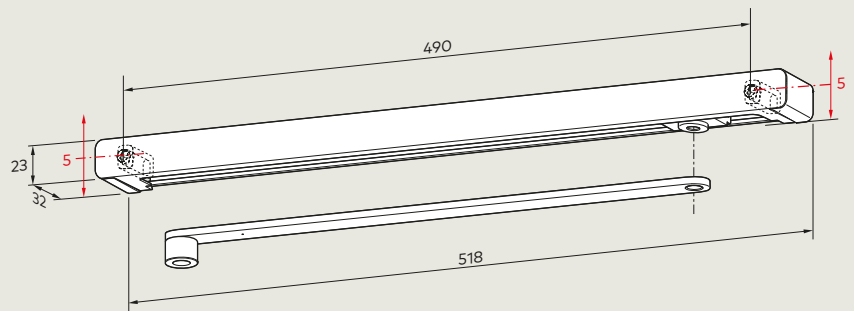

The G-N XEA includes the main arm, slide channel, slide block, fixings, screws and end caps. The G-N XEA slide channel can be used for both DIN-L and DIN-R doors and may be combined with all door closer versions in XEA design. Slotted holes in the fixings allow for discrepancies in the drill pattern to be evened out and maintains even spacing between the door closer and slide channel.

Two G-N XEA design variants are also available. One is for direct transom installation. The other is for door leaf installation on the push side using a shortened main arm to provide an attractively aligned channel.

Accessories for G-N XEA slide channel

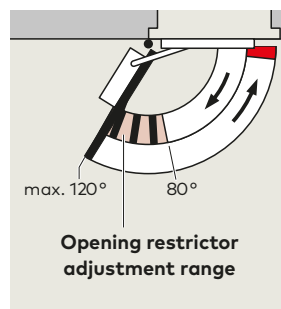
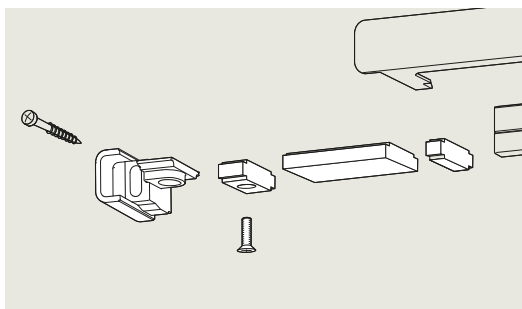

Opening restrictor

To be subsequently inserted into the slide channel. Adjustable between 80° and max. 120°. Using the opening restrictor will prevent a normally opened door from hitting surrounding walls.

The opening restrictor is not an overload protection mechanism and does not replace the door stop in many use cases.

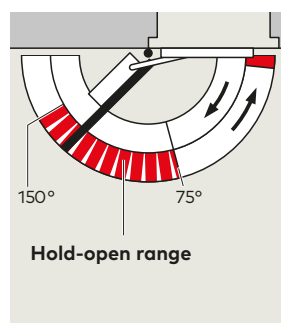
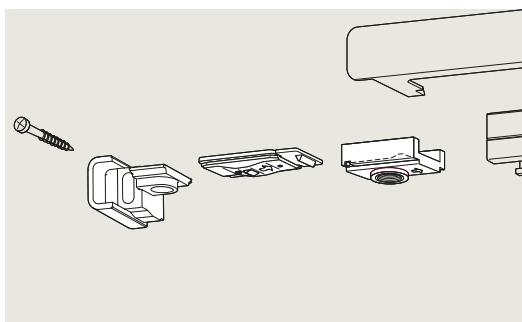

Hold-open unit RF

To be subsequently inserted into the slide channel. The hold-open unit RF allows for the door to be precisely held open without fallback at an opening angle up to approx. 150°. The hold-open feature can easily be enabled and disabled by the user as needed. The release force can be adapted to the door situation in question. RF unit is suitable for both DIN-L and DIN-R doors.

Not suitable for fire and smoke control doors.

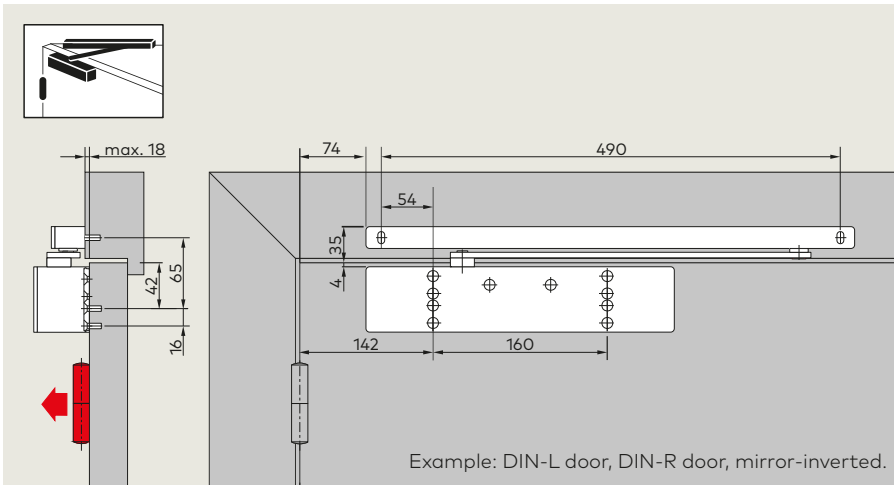

Door leaf installation, pull side

A 180° opening angle is possible in this installation type, provided that the appropriate construction conditions are met. In most cases, a wall recess is required for the door closer.

F Approval certification

The TS 98 XEA is inspected and quality tested according to EN 1154 by the National Materials Testing Office in Dortmund.

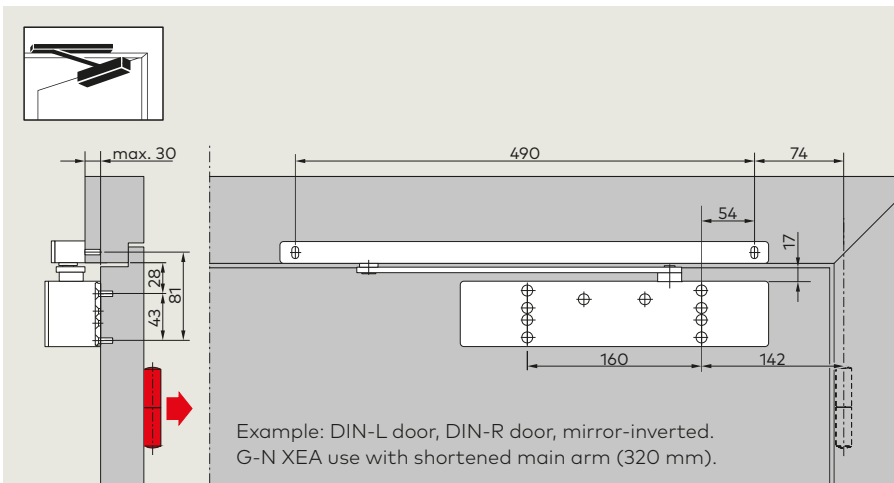

Door leaf installation, push side

Depending on construction conditions, the door opening angle is limited to approx. 120° to 145°. To prevent damage to the door and door closer, we recommend using a door stop.

A door stop must be placed on fire and smoke control doors.

F Approval certification

The TS 98 XEA is inspected and quality tested according to EN 1154 by the National Materials Testing Office in Dortmund. Approval certification associated with the respective fire or smoke control door is additionally required.

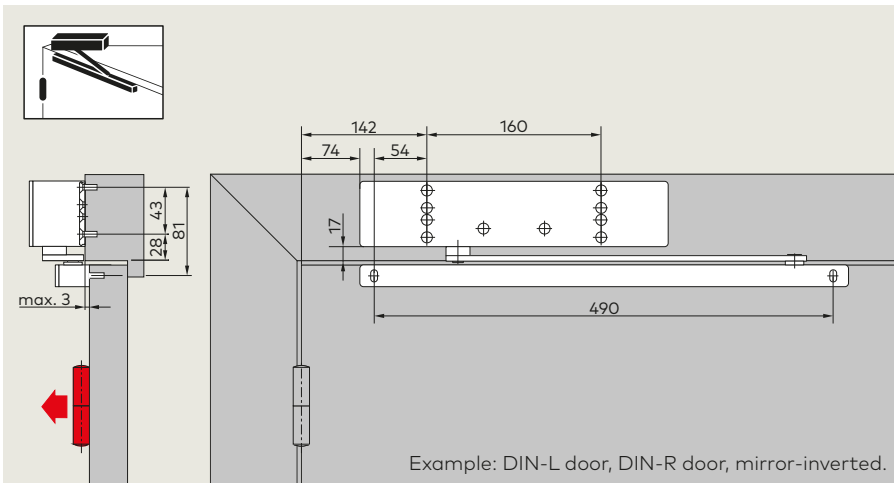

Transom installation, pull side

A 180° opening angle is possible in this installation type, provided that the appropriate construction conditions are met.

F Approval certification

The TS 98 XEA is inspected and quality tested according to EN 1154 by the National Materials Testing Office in Dortmund. Approval certification associated with the respective fire or smoke control door is additionally required.

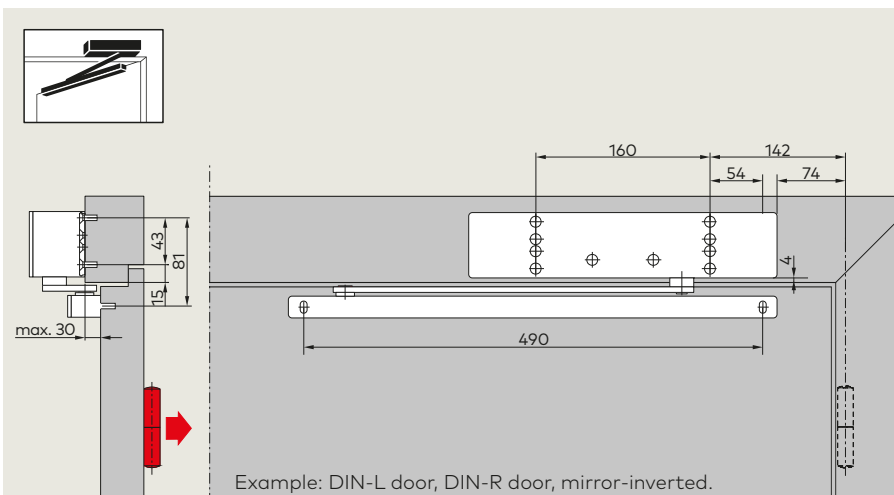

Transom installation, push side

Depending on construction conditions, the door opening angle is limited to approx. 120° to 145°. To prevent damage to the door and door closer, we recommend using a door stop.

F Approval certification

The TS 98 XEA is inspected and quality tested according to EN 1154 by the National Materials Testing Office in Dortmund. Approval certification associated with the respective fire or smoke control door is additionally required.

G-EMF XEA slide channel

with electromechanical hold-open unit

for 1-leaf doors

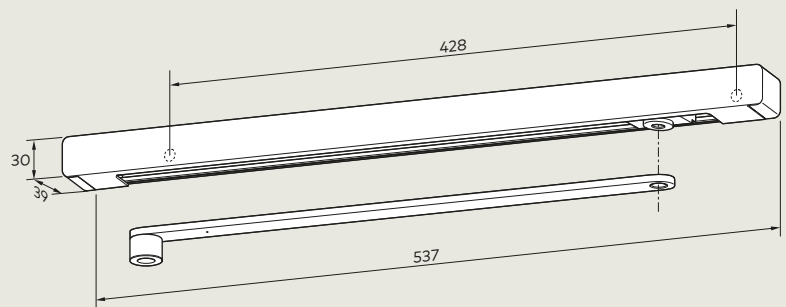
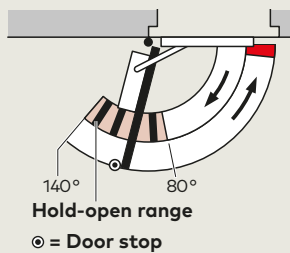

The G-EMF XEA allows for the door to be precisely held open without fallback. The hold-open position can be set to an opening angle between approx. 80° and 140°. The hold-open position is also the maximum door opening angle. To prevent damage to the door and door closer, we recommend using a door stop.

In case of alarm or power outage, the hold-open mechanism is disabled and the door is closed by the door closer. It can also be controlled via an external smoke detector (e.g. RMZ XEA). Thanks to the adjustable release force (no tools required), the hold-open unit can also be effortlessly released by hand.

The G-EMF XEA includes: Main arm, slide channel, slide block, electromechanical hold-open unit, cover, fastening screws and end caps. The G-EMF XEA slide channel is installed on the transom and is usable for both DIN-L and DIN-R doors.

For exceptionally large and heavy doors (over 1250 mm) or doors where the hold-open position is supposed to be above 140°, we recommend using EM electromagnets—in lieu of EMF—which may also use RMZ XEA smoke detector.

Technical data

Operating voltage	24 V DC, ± 15%
Power input	1.4 W
Duty cycle	100% CDF
Release torque	Adjustable

Pull side installation

TS 98 XEA door closer with G-EMF XEA

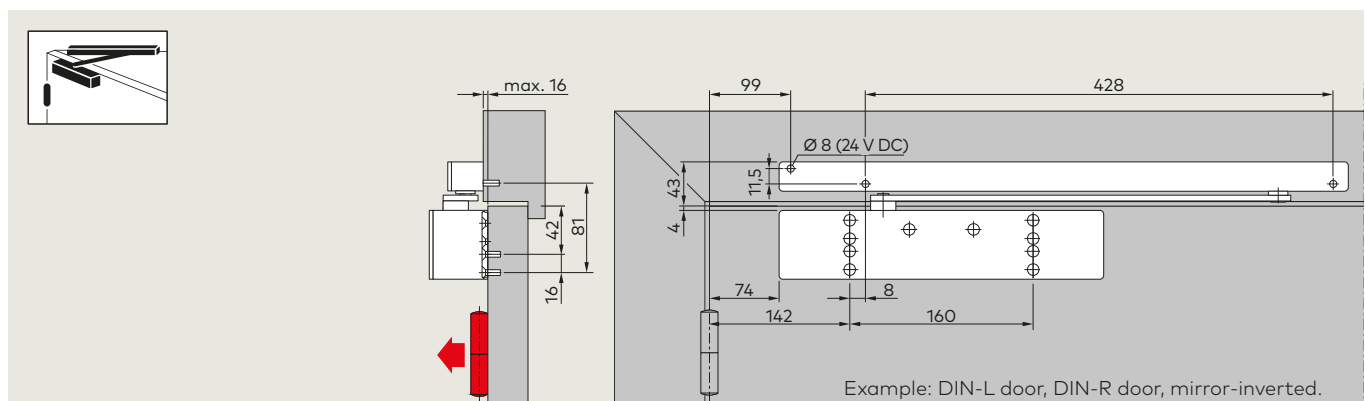

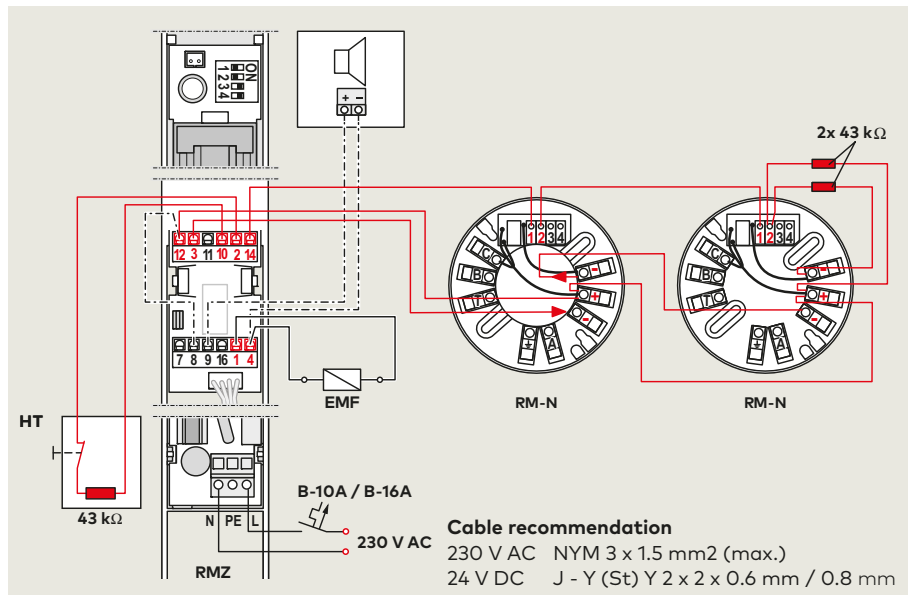
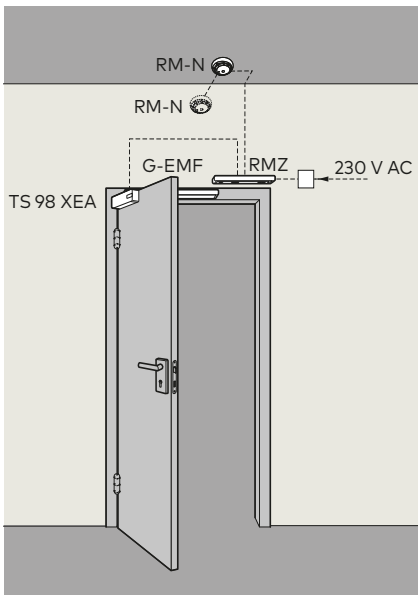

F Approval certification

The TS 98 XEA EMF is officially approved with all notable smoke detection systems by the German Institute for Structural Engineering; acceptance test required.

Regulations/information

The use of hold-open devices is subject to special regulations due to official approval requirements – see page 38/39.

Application example

Hold-open device on a fire and smoke control door, consisting of: TS 98 XEA door closer, G-EMF XEA, RMZ XEA smoke detector (smoke detector, trigger device and stabilized power supply for 24 V DC) as a transom-mounted smoke detector and 1 RM-N ceiling-mounted smoke detector for both sides of the door – see page 26/27.

Installation, push side

TS 98 XEA door closer with G-EMF XEA

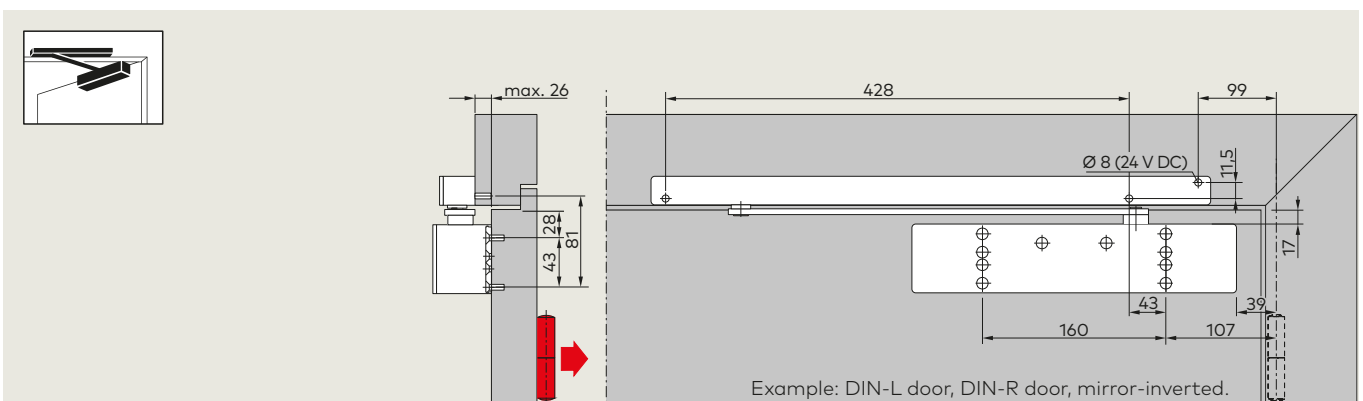

G-EMR XEA slide channel

with electromechanical hold-open unit and integrated smoke detector for 1-leaf doors

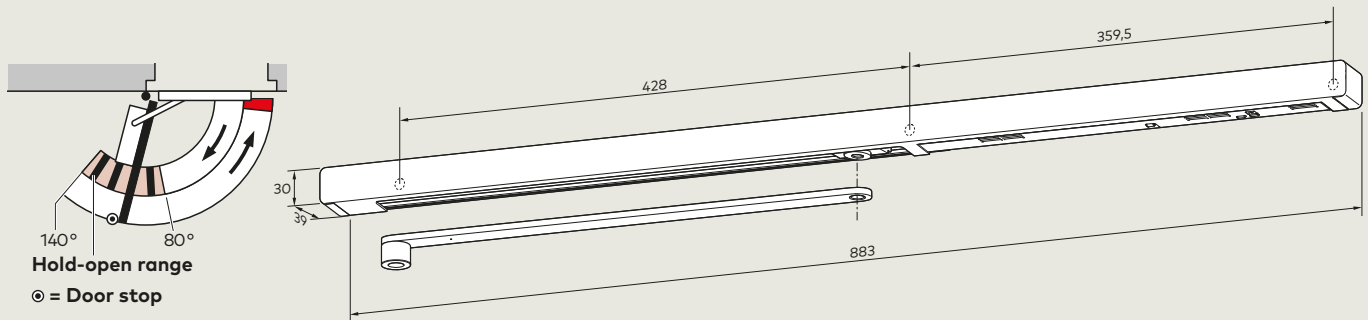

G-EMR XEA allows for fire and smoke control doors to be equipped in such a manner that they can be precisely held open and fully monitored and controlled independently of other systems. The hold-open position can be set to an opening angle between approx. 80° and 140°. To prevent damage to the door and door closer, we recommend using a door stop.

In case of alarm or power outage, the hold-open mechanism is disabled and the door is closed by the door closer. Thanks to the adjustable release force (no tools required), the hold-open unit can also be effortlessly released by hand.

The G-EMR XEA includes: Main arm, slide channel, slide block, electromagnetic hold-open unit, smoke detector, power supply, cover, fastening screws and end caps and is applicable for both DIN-L and DIN-R doors. The device has two separate LEDs that serve as an operation and maintenance indicator.

There are also connectors for additional detectors, an external manual trigger, along with potential-free alarm contact. For exceptionally large and heavy doors (over 1250 mm) or doors where the hold-open position is supposed to be above 140°, we recommend using EM electromagnets—in lieu of EMF—which may also use RMZ XEA smoke detector.

Technical data

Connection voltage	230 V AC ± 10%
Operating voltage (internal)	24 V DC
max. rated power output	9.8 W
EMF Power input	1.4 W
Duty cycle	100% CDF
Release torque	Adjustable

See page 26 for detailed technical information on the smoke detector

Pull side installation

TS 98 XEA door closer with G-EMR XEA

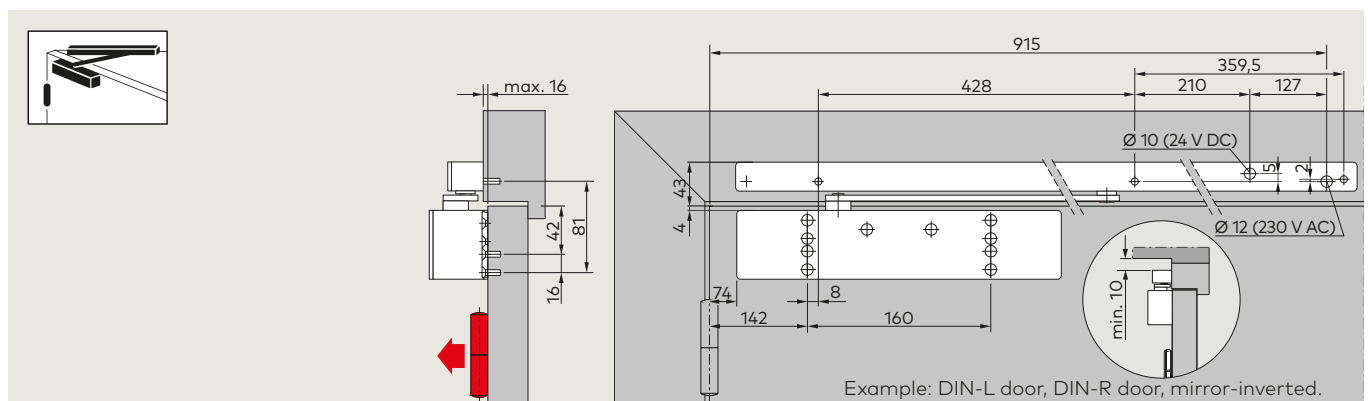

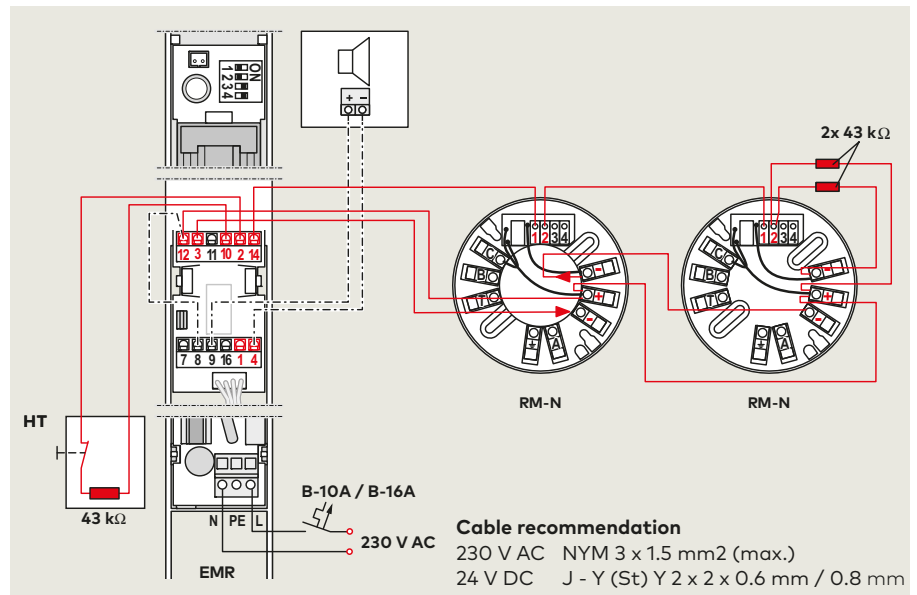
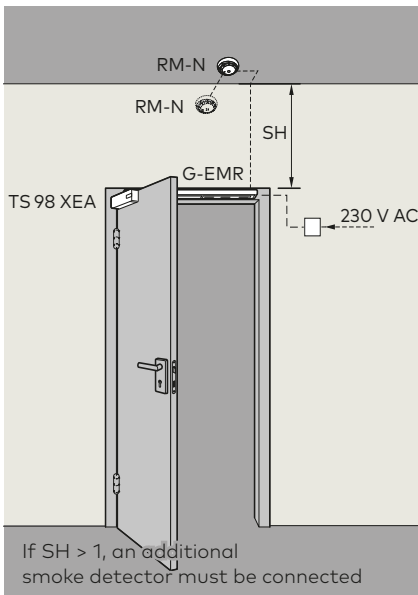

F Approval certification

The TS 98 XEA EMR is officially approved with all notable smoke detection systems by the German Institute for Structural Engineering; acceptance test required. When installing on the push side, proof of suitability associated with the respective fire or smoke control door is also required.

Application example

Hold-open device on a fire and smoke control door, consisting of: TS 98 XEA door closer, G-EMR XEA and 1 RM-N ceiling-mounted smoke detector for both sides of the door – see page 26/27.

Regulations/information

The use of hold-open devices is subject to special regulations due to official approval requirements – see page 38/39. The smoke detector unit must be replaced after 8 years as per DIN 14677. An LED will continuously indicate when the replacement date has been reached.

Installation, push side

TS 98 XEA door closer with G-EMR XEA

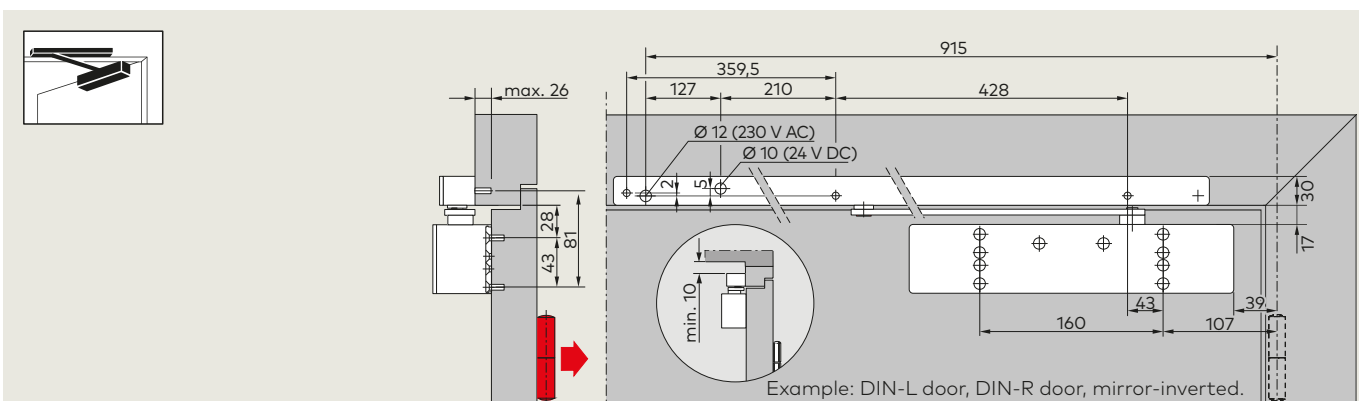

Door coordinator

for 2-leaf doors, for installation on the pull side

GSR XEA

Standard design

The GSR XEA ensures that the active leaf always closes after the inactive leaf in 2-leaf doors and stands out since it is equipped with a thrust rod clamping system. This system works independently from the door closer's hydraulics and ensures the highest level of safety and reliability (door does not "creep" to a close).

Overload protection protects the closing sequence control and door construction from damage. The GSR XEA door coordinator can be used for both DIN-L and DIN-R doors and is combined with TS 98 XEA door closers.

F Approval certification

The TS 98 XEA GSR is inspected and quality tested according to EN 1158 by the National Materials Testing Office in Dortmund. Approval certification associated with the respective fire or smoke control door is additionally required.

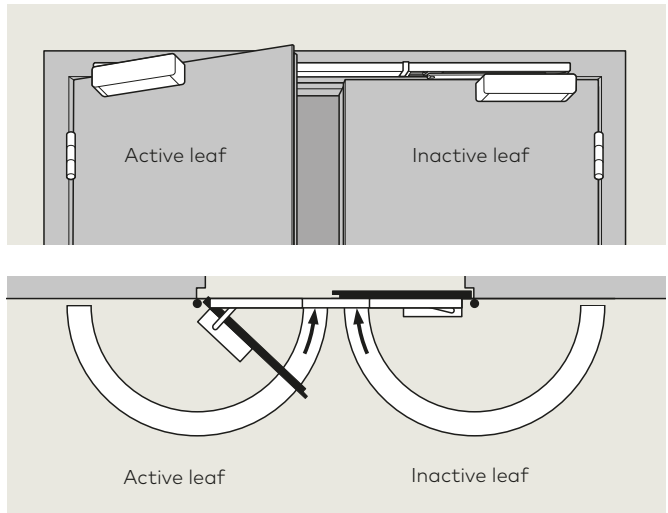

Pull side installation

TS 98 XEA door closer with GSR/GSR-EMF XEA

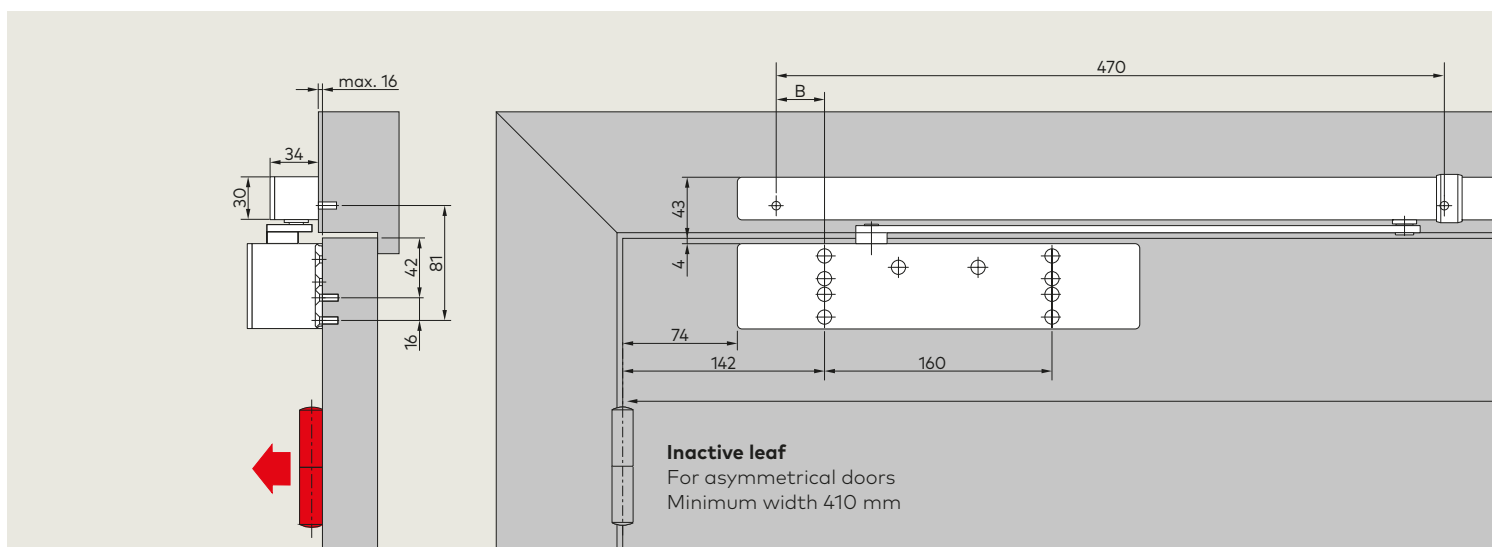

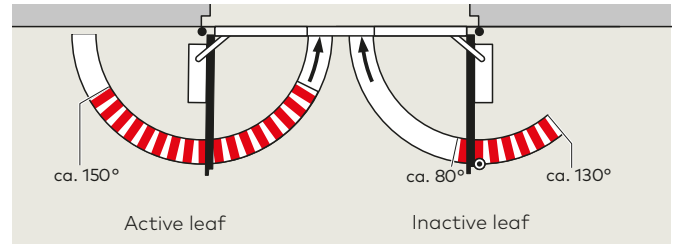
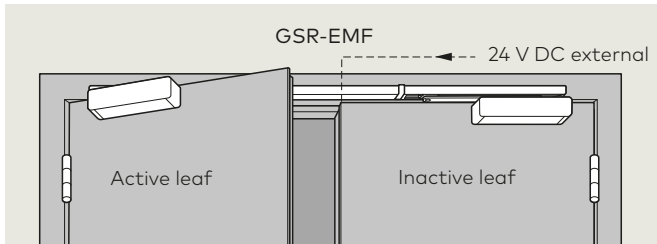

GSR-EMF XEA with electromechanical hold-open unit

The GSR-EMF XEA not only ensures the right order when closing the 2-leaf doors, it furthermore allows for the door leaves to be held open. In case of alarm or power outage, the hold-open unit is disabled and the door is closed by the door closer. It is controlled via an external smoke detector. Thanks to the adjustable release force (no tools required), the hold-open unit can also be effortlessly released by hand. The hold-open position is also the maximum door opening angle. To prevent damage to the door and door closer, we recommend using a door stop. For doors where the hold-open position is supposed to be above 130°, we recommend using EM electromagnets in lieu of an electromagnetic hold-open unit.

F Approval certification

The TS 98 XEA GSR-EMF 1, EMF 2 and EMF 1G are officially approved with all notable smoke detection systems by the German Institute for Structural Engineering; acceptance test required.

Regulations/information

The use of hold-open devices is subject to special regulations due to official approval requirements – see page 38/39.

Technical data

EMF operating voltage	24 V DC, ± 15%
Power input EMF 1	1.4 W
EMF 2	2.8 W
Duty cycle	100% CDF
Release torque	Adjustable

GSR-EMF 1 XEA

Active and inactive leaf can be simultaneously held open at a hold-open position between 80° and 130° (up to a max. of 150° for the active leaf)

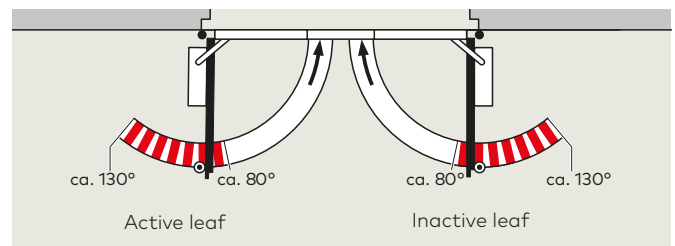

GSR-EMF 2 XEA

Active and inactive leaf can be independently held open at a hold-open position between 80° and 130°.

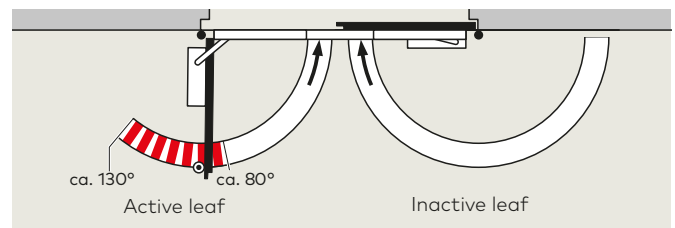

GSR-EMF 1G XEA

Only hold open the active leaf at any hold-open position between 80° and 130°. This door coordinator allows you to only hold open the active leaf in special door constructions, e.g. inactive leaf that is held open, narrow inactive leaf in asymmetrical doors, etc.

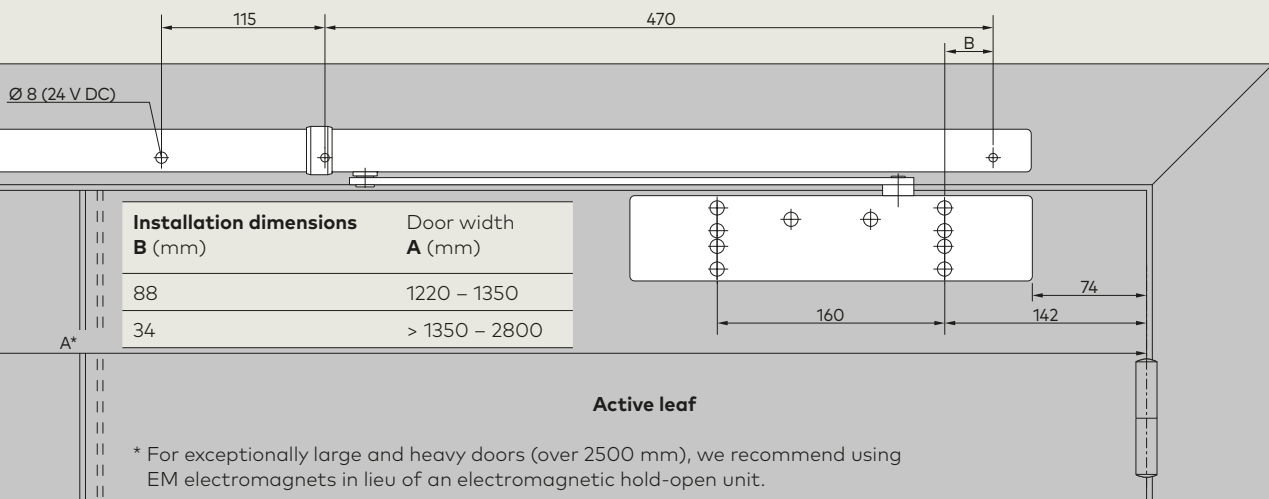

Door coordinator

for 2-leaf doors, for installation on the pull side

GSR-EMR XEA

with electromechanical hold-open unit and integrated smoke detector

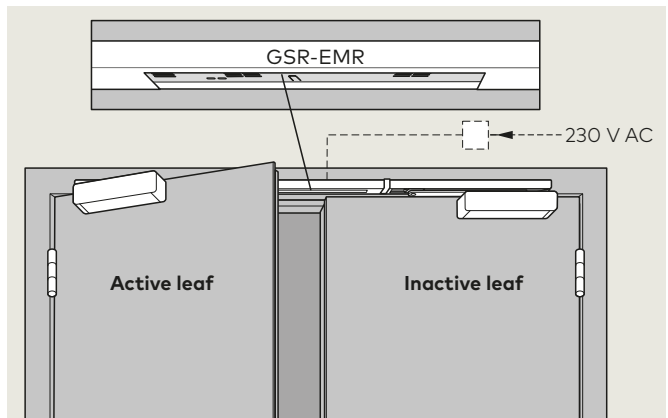

Not only does the GSR-EMR XEA ensure that the 2-leaf doors close in the correct order, it also allows for fire and smoke control doors to be equipped in such a manner that they can be precisely held open and fully monitored and controlled independently of other systems. In case of alarm or power outage, the hold-open unit is disabled and the door is closed by the door closer. Thanks to the adjustable release force (no tools required), the hold-open mechanism can also be effortlessly released by hand. The hold-open position is also the maximum door opening angle. To prevent damage to the door and door closer, we recommend using a door stop.

There are also connectors for additional detectors, an external manual trigger, along with potential-free alarm contact. For exceptionally large and heavy doors (over 1250 mm) or doors where the hold-open position is supposed to be above 130°, we recommend using EM electromagnets—in lieu of the EMR—which may also use the RMZ XEA smoke detector. The device has two separate LEDs that serve as an operation and maintenance indicator.

Pull side installation

TS 98 XEA door closer with GSR-EMR XEA

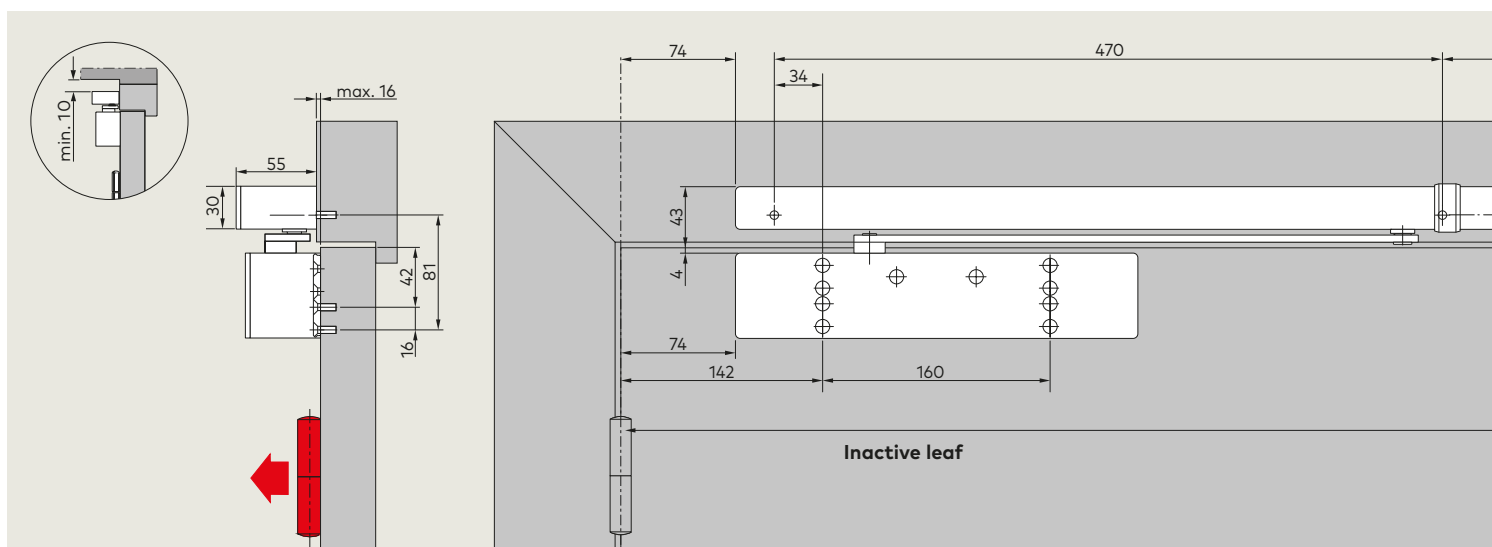

F Approval certification

The TS 98 XEA, GSR-EMR 1 XEA, EMR 2 XEA and EMR 1G XEA are officially approved with all notable smoke detection systems by the German Institute for Structural Engineering; acceptance test required.

Regulations/information

The use of hold-open devices is subject to special regulations due to official approval requirements – see page 38/39. The smoke detector unit must be replaced after 8 years as per DIN 14677. An LED will continuously indicate when the replacement date has been reached.

Technical data

Connection voltage	230 V AC \pm 10%
Operating voltage (internal)	24 V DC
max. rated power output	9.8 W
Power input EMR 1	1.4 W
EMR 2	2.8 W
Duty cycle	100% CDF
Release torque	Adjustable

See page 26 for detailed technical information on the smoke detector

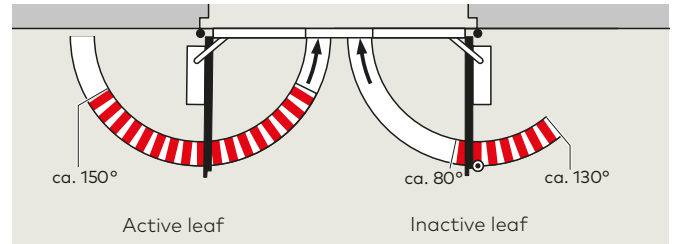

GSR-EMR 1 XEA

Active and inactive leaf can be simultaneously held open at a hold-open position between 80° and 130° (up to a max. of 150° for the active leaf)

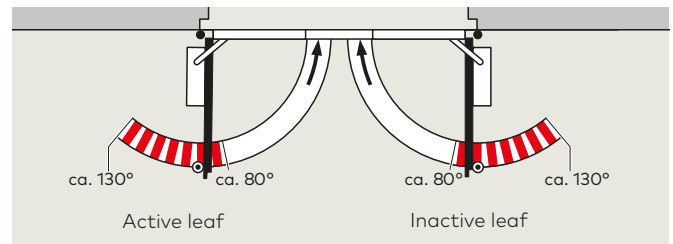

GSR-EMR 2 XEA

Active and inactive leaf can be independently held open at a hold-open position between 80° and 130°.

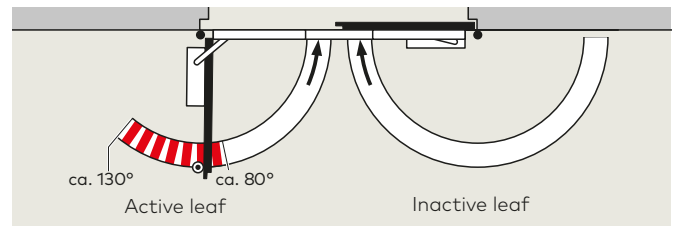

GSR-EMR 1G XEA

Only hold open the active leaf at any hold-open position between 80° and 130°. This door coordinator allows you to only hold open the active leaf in special door constructions, e.g. inactive leaf that is held open, narrow inactive leaf in asymmetrical doors, etc.

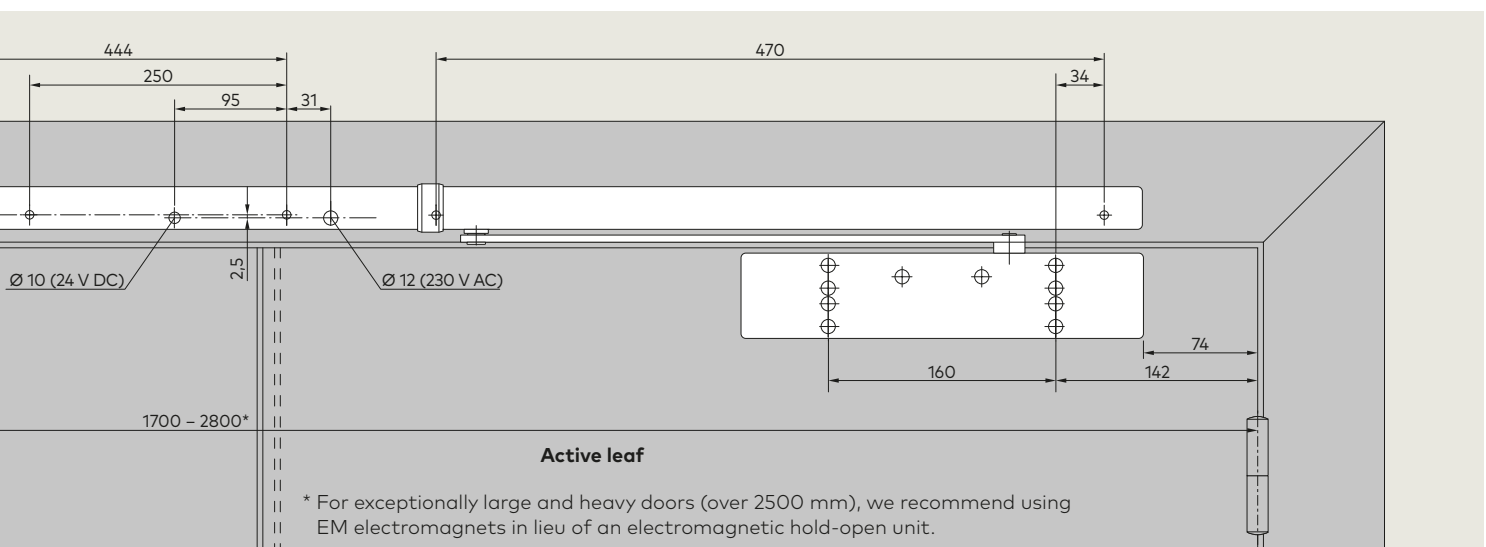

Door coordinator

for 2-leaf doors, for installation on the push side BG

GSR XEA BG

Standard design

The GSR XEA ensures that the active leaf always closes after the inactive leaf in 2-leaf doors and stands out since it is equipped with a thrust rod clamping system. This system works independently from the door closer's hydraulics and ensures the highest level of safety and reliability (door does not "creep" to a close). Overload protection protects the closing sequence control and door construction from damage. The GSR XEA BG door coordinator can be used for both DIN-L and DIN-R doors and is combined with TS 98 XEA door closers.

The maximum door opening angle is approx. 120°. To prevent damage to the door and door closer, we recommend using a door stop. The use of TS 98 XEA GSR on the pull side is recommended for panic applications on the fire and smoke control doors.

F Approval certification

The TS 98 XEA GSR is inspected and quality tested according to EN 1158 by the National Materials Testing Office in Dortmund. Approval certification associated with the respective fire or smoke control door is additionally required.

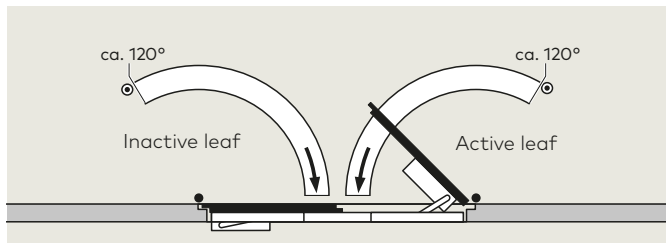
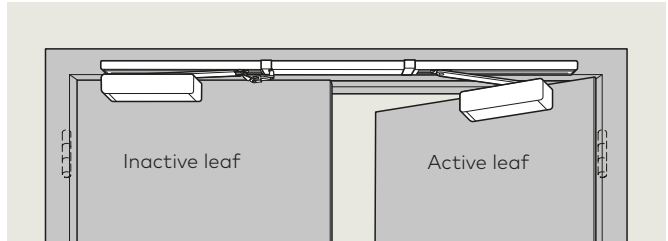

Installation, push side

TS 98 XEA door closer with GSR XEA BG/GSR-EMF XEA BG

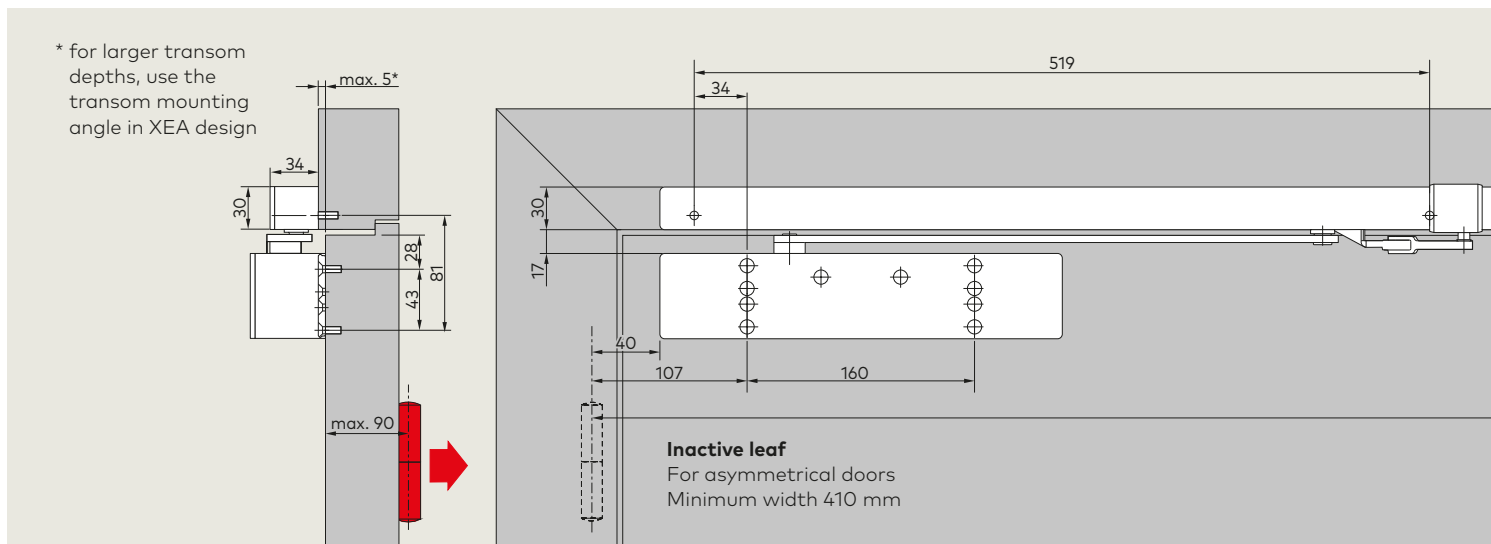

GSR-EMF 2 XEA BG

with electromechanical hold-open unit

The GSR-EMF XEA not only ensures the right order when closing the 2-leaf doors, it furthermore allows for the door leaves to be held open. In case of alarm or power outage, the hold-open unit is disabled and the door is closed by the door closer. It is controlled via external smoke detectors. Thanks to the adjustable release force (no tools required), the hold-open unit can also be effortlessly released by hand. The hold-open position is also the maximum door opening angle. To prevent damage to the door and door closer, we recommend using a door stop.

F Approval certification

The TS 98 XEA GSR-EMF 2 XEA BG is officially approved with all notable smoke detection systems by the German Institute for Structural Engineering; acceptance test required.

Regulations/information

The use of hold-open devices is subject to special regulations due to official approval requirements – see page 38/39.

Technical data

EMF operating voltage	24 V DC, $\pm 15\%$
Power input EMF 1	1.4 W
EMF 2	2.8 W
Duty cycle	100% CDF
Release torque	Adjustable

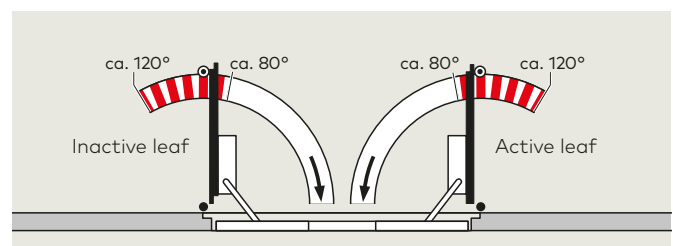
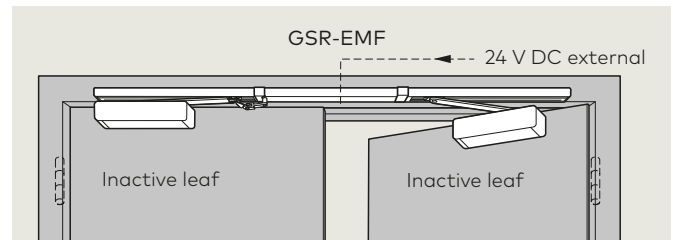

GSR-EMF 2 XEA BG

Active and inactive leaf can be independently held open at a hold-open position between 80° and 120°.

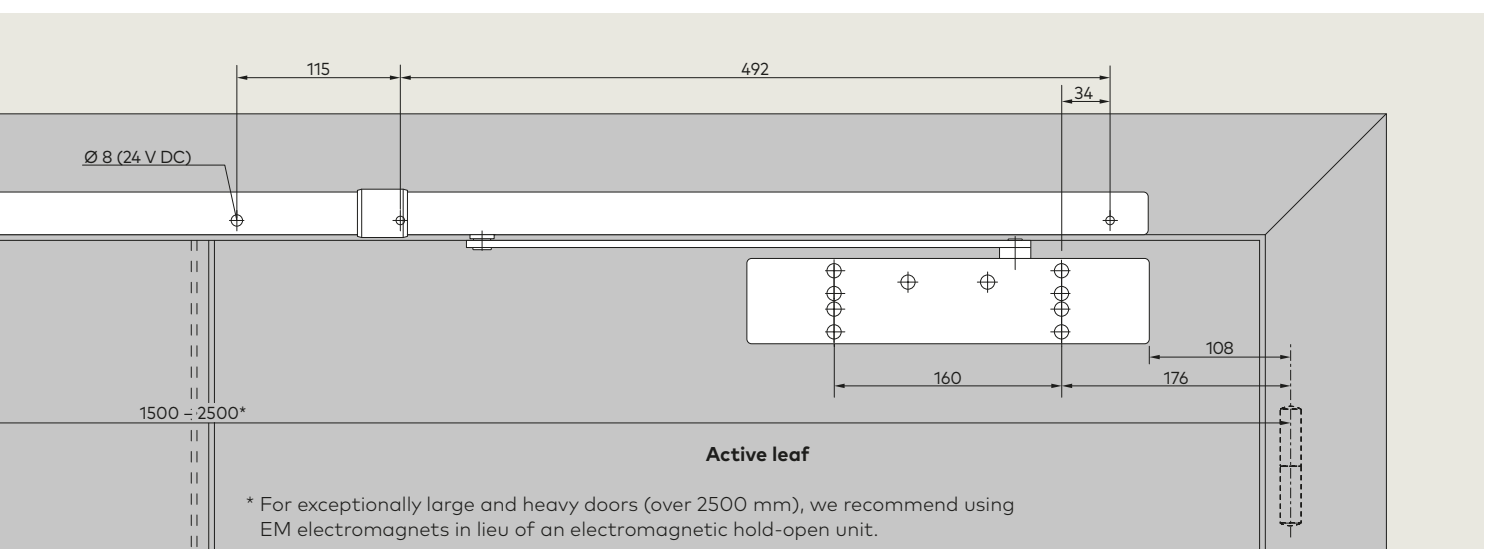

Door coordinator

for 2-leaf doors, for installation on the push side BG

GSR-EMR XEA BG

with electromechanical hold-open unit and integrated smoke detector

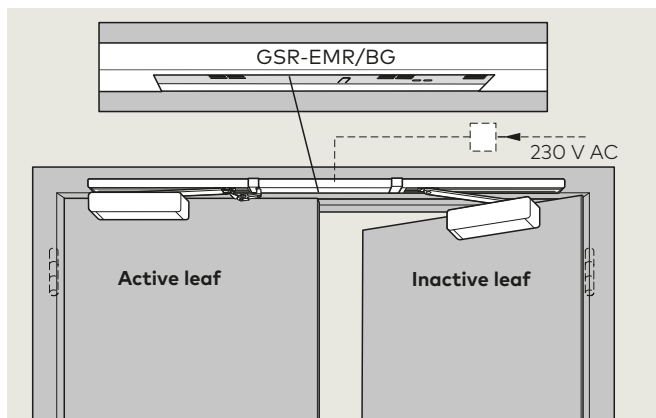

Not only does the GSR-EMR XEA ensures that the 2-leaf doors close in the correct order, it also allows for fire and smoke control doors to be equipped in such a manner that they can be precisely held open and fully monitored and controlled independently of other systems. In case of alarm or power outage, the hold-open unit is disabled and the door is closed by the door closer. Thanks to the adjustable release force (no tools required), the hold-open unit can also be effortlessly released by hand. The hold-open position is also the maximum door opening angle. To prevent damage to the door and door closer, we recommend using a door stop.

There are also connectors for additional detectors, an external manual release, along with potential-free alarm contact. For exceptionally large and heavy doors (over 1250 mm) or doors where the hold-open position is supposed to be above 130°, we recommend using EM electromagnets—in lieu of the EMR—which may also use the RMZ XEA smoke detector. The device has two separate LEDs that serve as an operation and maintenance indicator.

Installation, push side

TS 98 XEA door closer with GSR-EMR XEA BG

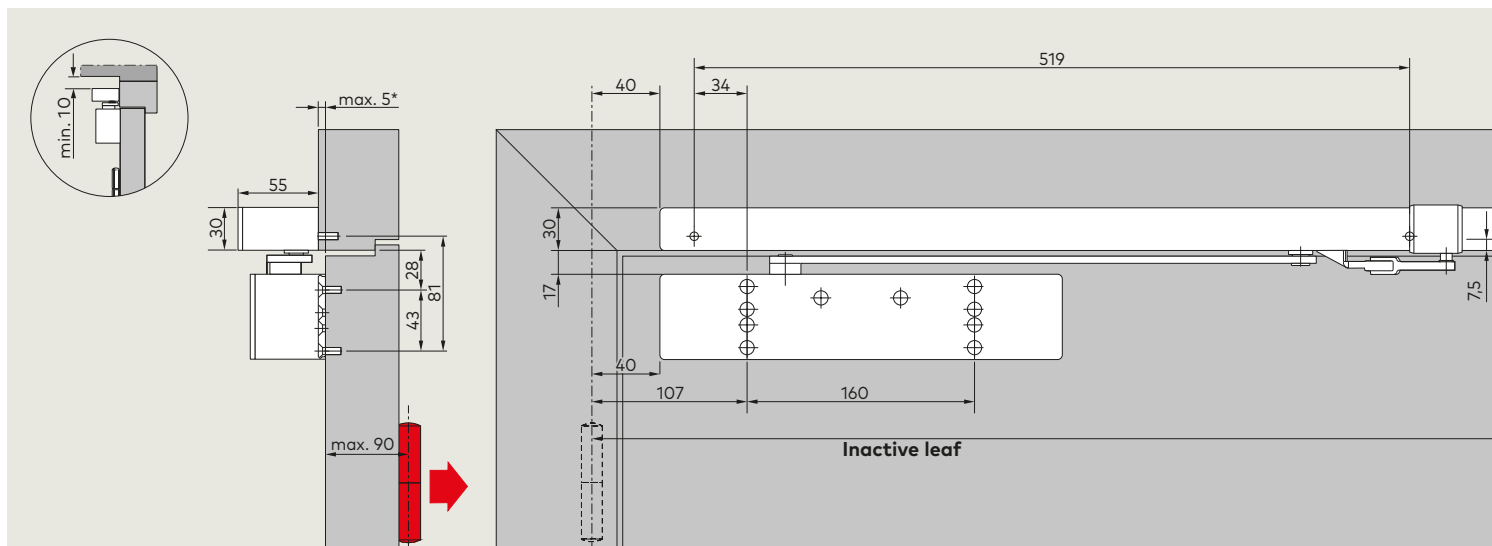

F Approval certification

The TS 98 XEA GSR-EMR 2 XEA BG is officially approved with all notable smoke detection systems by the German Institute for Structural Engineering; acceptance test required.

Regulations/information

The use of hold-open devices is subject to special regulations due to official approval requirements – see page 38/39. The smoke detector unit must be replaced after 8 years as per DIN 14677. An LED will continuously indicate when the replacement date has been reached.

Technical data

Connection voltage	230 V AC \pm 10%
Operating voltage (internal)	24 V DC
max. rated power output	9.8 W
Power input EMR 1	1.4 W
EMR 2	2.8 W
Duty cycle	100% CDF
Release torque	Adjustable

See page 26 for detailed technical information on the smoke detector

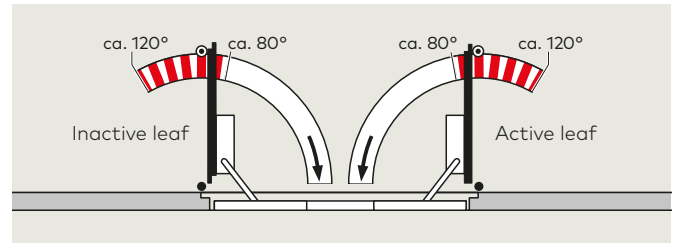

GSR-EMR 2 XEA BG

Active and inactive leaf can be independently held open at a hold-open position between 80° and 120°.

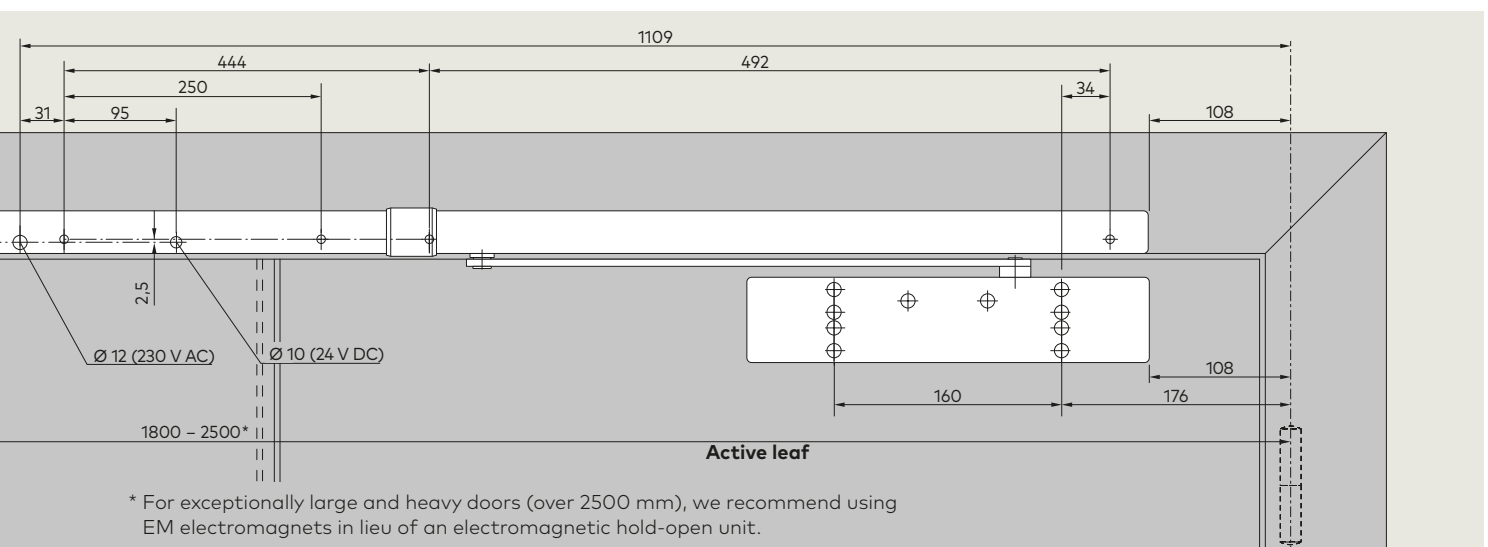

RMZ XEA Smoke detector

RM-N Smoke detector

Data and features		RMZ XEA	RM-N
Functions	Smoke detector	●	●
	Trigger mechanism	●	-
	Power supply	●	-
Smoke detection	Scattered-light principle (optical)	●	●
Installation	Transom installation	●	-
	Ceiling mounting	-	●
Connect additional detectors		●	-
Total connected load (max.) for hold-open device and additional detectors in W		9.8	-
Power input internal detector in W		1.2	0.65
LED Indicators	Alarm	●	●
	Operation	●	-
	Maintenance	●	-
	Contamination	●	-
Input voltage		230 V AC ± 10 %	24 V DC +15%, -10%
Output voltage		24 V DC	-
Detector operating voltage		24 V DC +15%, -10%	24 V DC
Power consumption (max.) in mA		75	20
Potential-free changeover contact Extra-low voltage (SELV)		24 V AC/DC 1 A	30 V AC/DC 1 A
Reset	automatically changeable to manual reset	●	●
		●	-
Function check	Flue gas	●	●
Connecting terminals for external manual trigger		●	-
Protection class		IP 30	IP 43
Ambient temperature in °C		-20, +40	-10, +60
Weight in kg		0.25	0.15
Dimensions in mm	Length	397	∅ 100
	Depth	34	
	Height	30	44
Tested according to EN 54 part 7		●	●
CE-mark for building products		●	●

● Yes - No

The RMZ XEA smoke detector and the RM-N smoke detector ideally supplement the proven, practical TS 98 XEA system for preventative fire protection. They are designed in accordance with the German Institute for Structural Engineering's latest guidelines and guarantee excellent interoperability among all devices for holding open fire and smoke control doors under many different conditions.

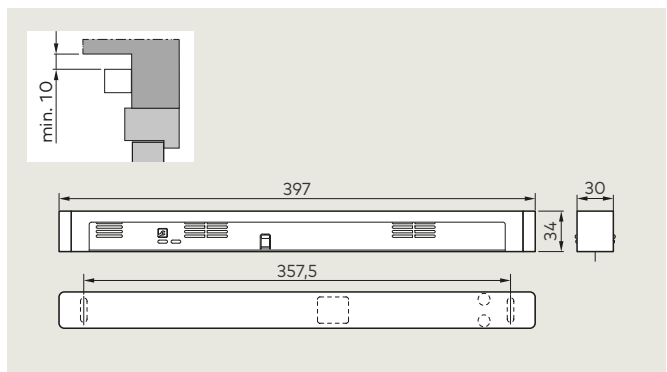

RMZ XEA Smoke detector

The RMZ smoke detector in XEA design supplies connected hold-open devices with 24 V direct current and cuts power to it in case of alarm or in case of a power outage (triggering). It is automatically reset, although it can be switched to manual reset. There are also connectors for additional detectors and for an external manual trigger. The smoke detector has an RMZ XEA design with a stabilized power supply. The device has two separate LEDs that serve as an operating and maintenance indicator.

F Approval certification

The RMZ XEA is officially approved with all notable smoke detection systems by the German Institute for Structural Engineering; acceptance test required.

Regulations/information

The smoke detector unit must be replaced after 8 years as per DIN 14677. An LED will continuously indicate when the replacement date has been reached.

Connection diagram example, RMZ XEA with 2x RM-N

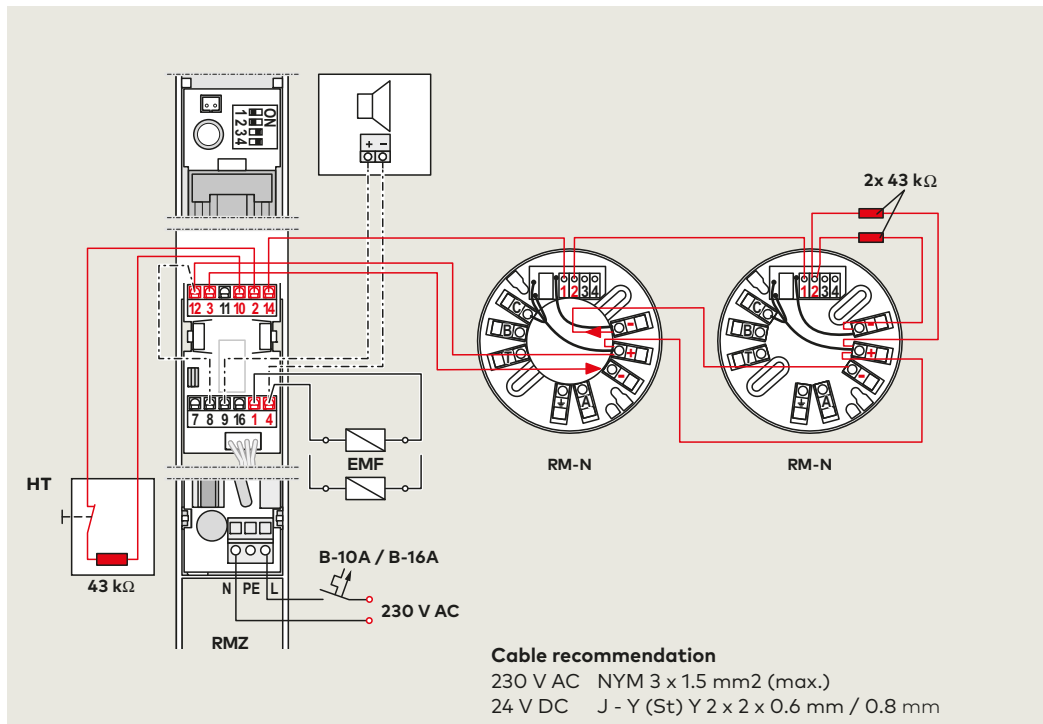
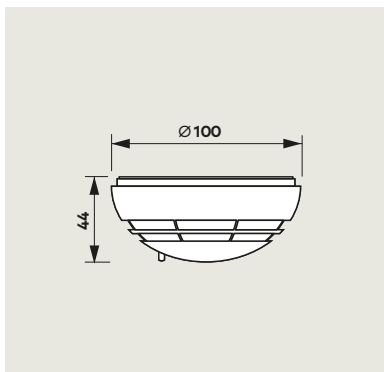

RM-N smoke detector

The RM-N smoke detector senses both smoldering and open, developing fires early and can be connected to all dormakaba hold-open systems.

Connection diagram, GSR-EMR XEA with 2x RM-N

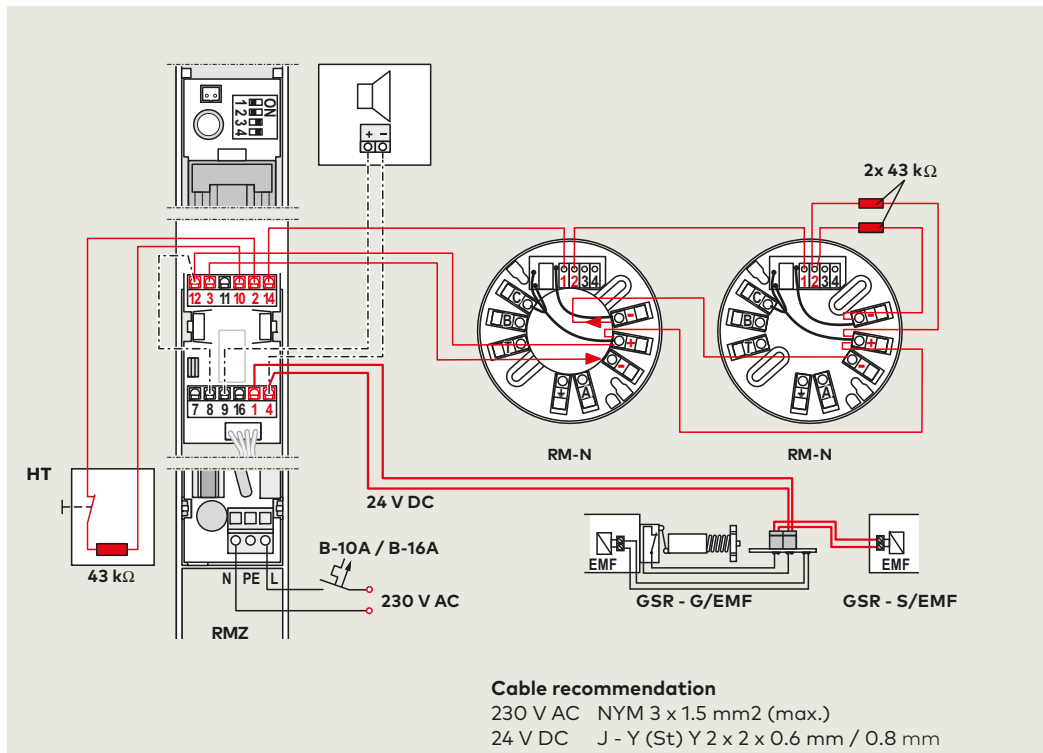

Accessories

1-leaf doors

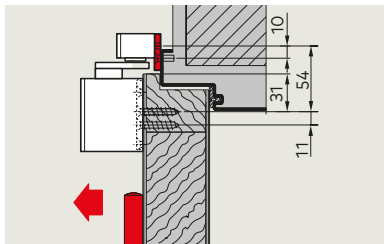

30 mm mounting plate for G-N XEA

For installing the slide channel on door frames where direct installation is not possible.

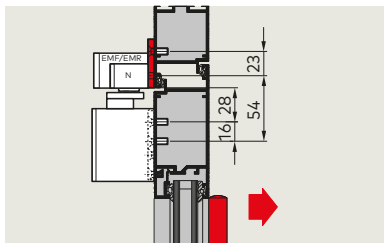
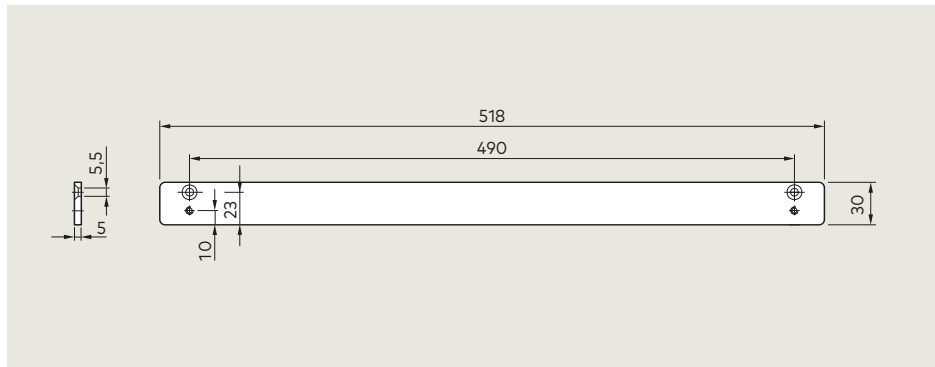

40 mm mounting plate for G-N XEA, EMF XEA, EMR XEA

For installing the slide channel on door frames where direct installation is not possible.

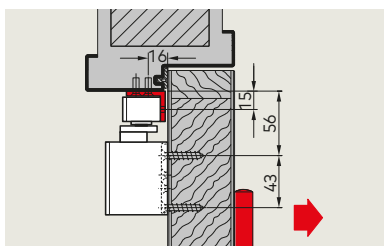
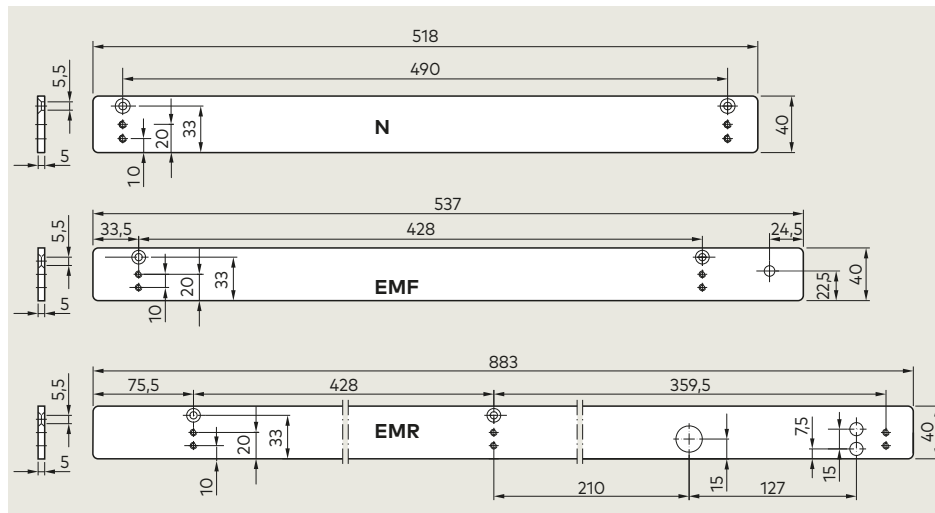

Transom mounting angle for G-N XEA

For installing the slide channel on door frames with a deep transom when installing on the push side. G-N XEA design variant for direct transom installation also available.

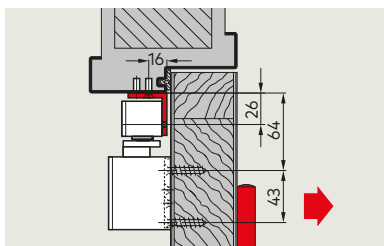
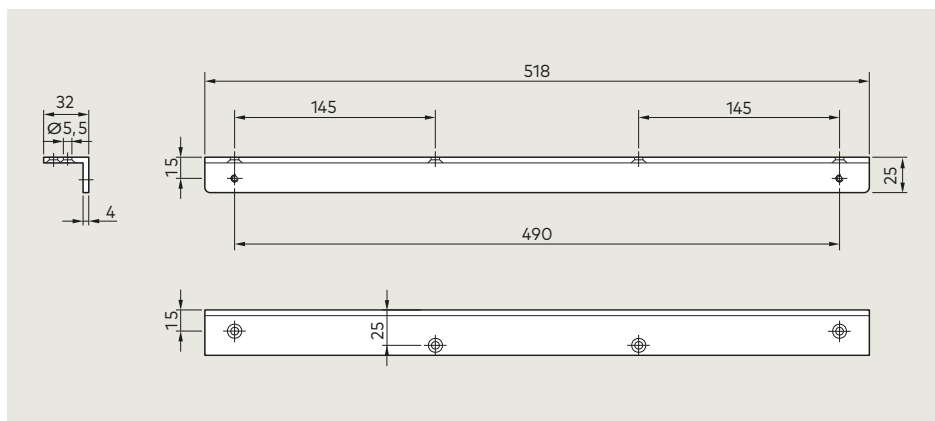

Transom mounting angle for G-EMF XEA

For installing the slide channel on door frames with a deep transom when installing on the push side.

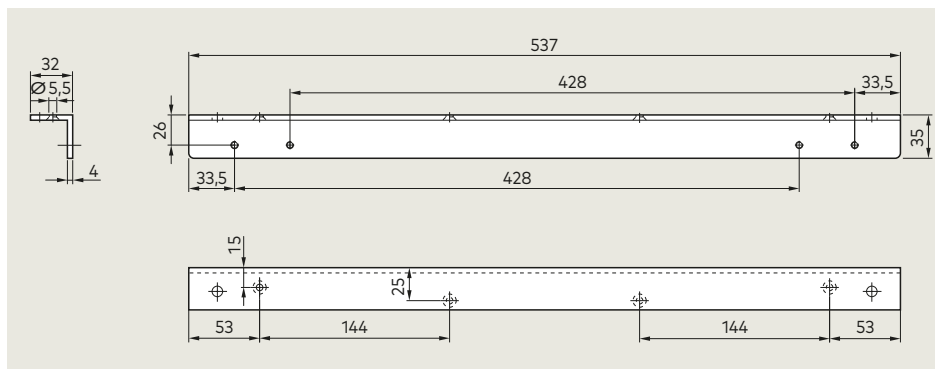

Accessories

2-leaf doors

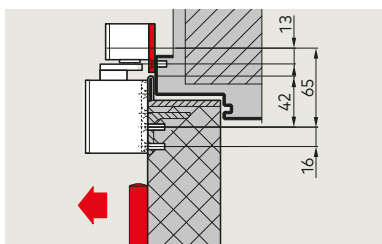

40 mm mounting plate for GSR XEA

For installing the slide channels on door frames where direct installation is not possible.

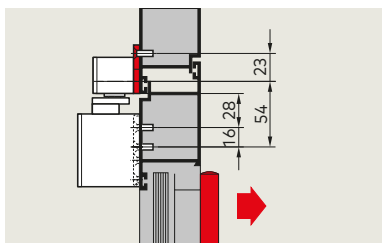

40 mm mounting plate for GSR XEA/BG

For installing the slide channels on door frames where direct installation is not possible.

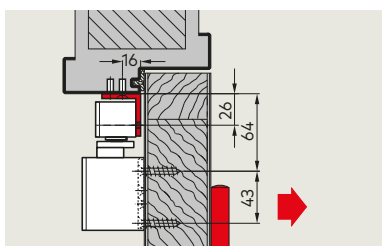





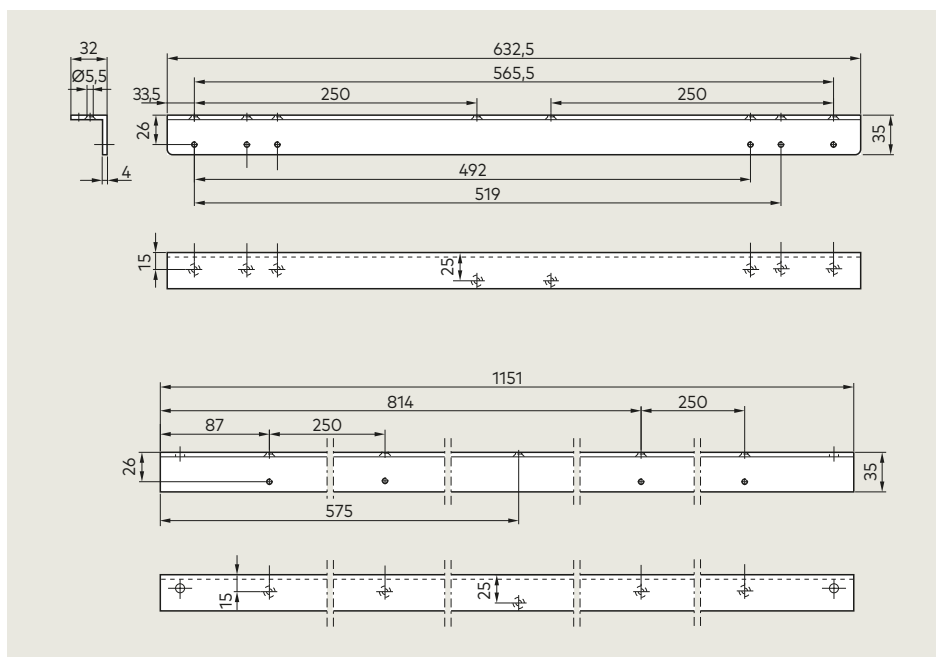
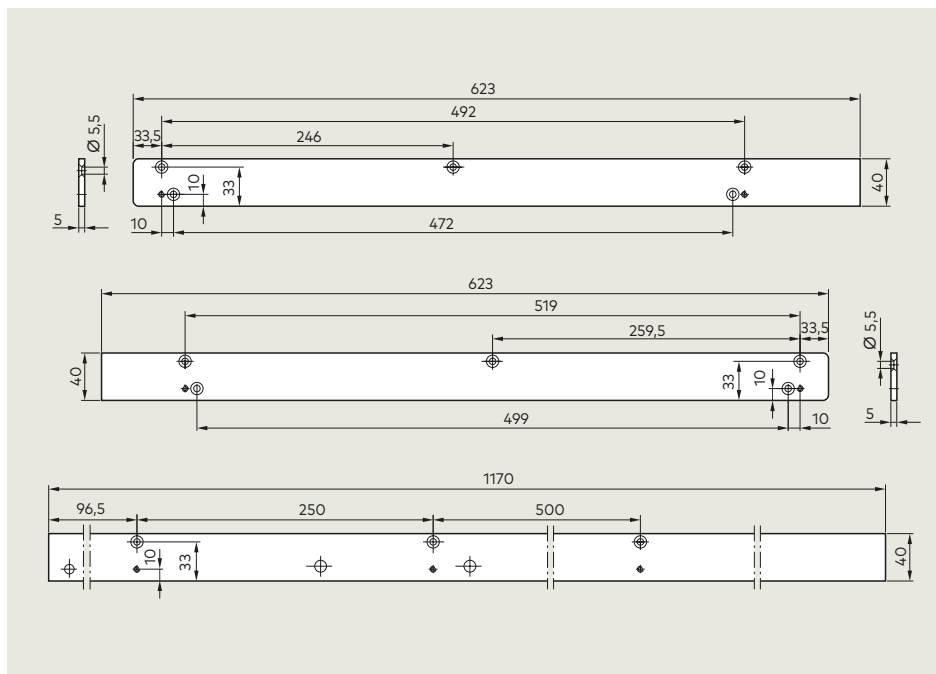
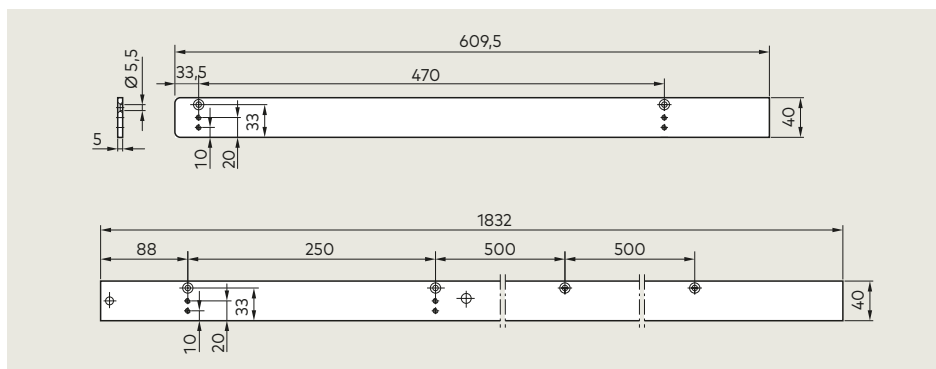



Transom mounting angle for GSR XEA/BG

For installing the slide channel on door frames with a deep transom.







Scope of delivery and accessories

1-leaf doors

			TS 98 XEA  EN 1-6 with mounting plate ■ 441101xx	Mounting plate 30 mm for G-N XEA 	Mounting plate 40 mm for G-N XEA 
	For product description, see page		10	30	30
G-N XEA 	□ 570100xx	12	□	■	△
G-N XEA for transom installation 	□ 570400xx	12	□	■	
G-N XEA with 320 mm main arm 	□ 570500xx		□	■	
G-EMF XEA 	□ 570800xx	14	□	■	
G-EMR XEA 	□ 570700xx	16	□	■	

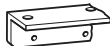
- Hold-open device
- Smoke detector
- xx See color options for item number extension
- Closing contact sold separately
- Slide channel sold separately
- △ Accessories

Mounting plate 40 mm for G-EMF XEA	Mounting plate 40 mm for G-EMR XEA	Transom mounting angle for G-N XEA	Transom mounting angle for G-EMF XEA	Opening restrictor for G-N XEA	RF unit for G-N XEA
					
574200xx	574600xx	574300xx	574400xx	35800093	18570000
30	30	30	30	12	12
		△		△	△
				△	△
				△	△
△			△		
	△				

Smoke detection system

RMZ XEA
648000xx



RM-N
64830900
VE = 2 units

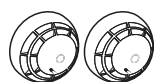

For product description, see page 26







xx Color options

- 01 Silver similar to RAL 9006 (P 600)
- 11 White similar to RAL 9016 (P 100)
- 10 White similar to RAL 9010 (P 210)
- 19 Black similar to RAL 9005 (P 190)
- 08 Customer Confection
(available only for TS 98 XEA and G-N XEA)
- 09 Special color
Also available in design version*
- 04 Stainless steel design (P 700)
- 05 Gold (P 750)

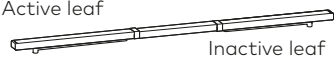
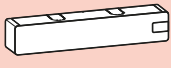
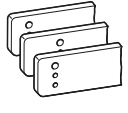
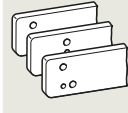
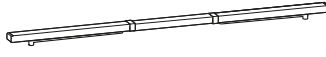
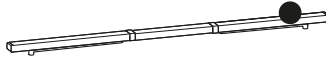
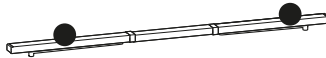
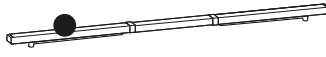
* "Design" refers to the products' surface design
Color availability depends on the product variant

Scope of delivery and accessories

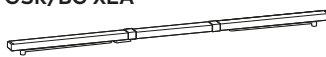
2-leaf doors

		TS 98 XEA	Mounting plates for GSR XEA	Mounting plates for GSR XEA/BG		
		 EN 1-6 mit Montageplatte ■ 441101xx	 574800xx	 574900xx		
For product description, see page		10	31	31		
GSR XEA 	<input type="checkbox"/> VK 571010xx <input type="checkbox"/> V 571020xx <input type="checkbox"/> VL 571030xx	20	<input type="checkbox"/>	2 x ■	△	
GSR-EMF 1 XEA 	<input type="checkbox"/> VK 571110xx <input type="checkbox"/> V 571120xx <input type="checkbox"/> VL 571130xx	21	<input type="checkbox"/>	2 x ■	△	
GSR-EMF 2 XEA 	<input type="checkbox"/> VK 571310xx <input type="checkbox"/> V 571320xx <input type="checkbox"/> VL 571330xx	21	<input type="checkbox"/>	2 x ■	△	
GSR-EMF 1G XEA 	<input type="checkbox"/> VK 571210xx <input type="checkbox"/> V 571220xx <input type="checkbox"/> VL 571230xx	21	<input type="checkbox"/>	2 x ■	△	
GSR-EMR 1 XEA 	<input type="checkbox"/> V 572150xx <input type="checkbox"/> VL 572160xx	22	<input type="checkbox"/>	2 x ■	△	
GSR-EMR 2 XEA 	<input type="checkbox"/> V 572350xx <input type="checkbox"/> VL 572360xx	22	<input type="checkbox"/>	2 x ■	△	
GSR-EMR 1G XEA 	<input type="checkbox"/> V 572250xx <input type="checkbox"/> VL 572260xx	22	<input type="checkbox"/>	2 x ■	△	
GSR/BG XEA 	<input type="checkbox"/> V 571440xx	24	<input type="checkbox"/>	2 x ■		△
GSR-EMF 2 XEA/BG 	<input type="checkbox"/> V 571740xx	25	<input type="checkbox"/>	2 x ■		△
GSR-EMR 2 XEA/BG 	<input type="checkbox"/> V 572770xx	26	<input type="checkbox"/>	2 x ■		△

Transom mounting angle for GSR XEA/BG



Opening restrictor

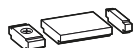

574700xx

18020000

31

12

△

△

△

- Hold-open device
- Smoke detector
- xx See color options for item number extension
- Closing contact sold separately
- Slide channel sold separately
- △ Accessories

xx Color options

- 01 Silver similar to RAL 9006 (P 600)
- 11 White similar to RAL 9016 (P 100)
- 10 White similar to RAL 9010 (P 210)
- 08 Customer Confection (available only for TS 98 XEA)
- 09 Other colors
- Also available in design version*
- 04 Stainless steel design
- 05 Gold (P 750)

* "Design" refers to the products' surface design
Color availability depends on the product variant

Smoke detection system

RMZ XEA
578000xx

RM-N
64830900
VE = 2 units



For product description, see page 26

		Door width (mm)	
		B	BG
GSR XEA/ GSR-EMF XEA	VK	1220 – 1350	–
	V	>1350 – 2500	1500 – 2500
	VL	>2500 – 2800	–
GSR-EMR XEA	V	1700 – 2500	1800 – 2500
	VL	>2500 – 2800	–

Specification texts

1-leaf doors

TS 98 XEA EN 1-6

Slide channel door closer according to EN 1154, with CE mark, in XEA design, including rapidly decreasing opening torque for easy door opening according to DIN SPEC 1104. Installation types: Normal installation on the pull and push side, transom installation on the pull and push side. Closing speed, 2. 15°–0° doorway, latching speed (SoftFlow), hydraulically controlled opening dampening and delayed closing can be comfortably adjusted from the front via a valve. EN 1–6 closing force can be configured from the front using a cordless screwdriver, includes visual closing force indicator. Installation console with universal hole pattern system. Suitable for DIN-L and DIN-R. Height-adjustable slide channel.

Color

- Silver colored similar to RAL 9006 (P 600)
- White similar to RAL 9016 (P 100)
- White similar to RAL 9010 (P 210)
- Black similar to RAL 9005 (P 190)
- Stainless steel design (P 700)
- Gold (P 750)
- Other colors

TS 98 XEA EMF

Slide channel door closer according to EN 1154, with CE mark, in XEA design, including rapidly decreasing opening torque for easy door opening according to DIN SPEC 1104. Installation types: Normal installation on the pull and push side. Closing speed, 2. 15°–0° closing range, latching speed (SoftFlow), hydraulically controlled opening dampening and delayed closing can be comfortably adjusted from the front via a valve. EN 1–6 closing force can be configured from the front using a cordless screwdriver, includes visual closing force indicator. Installation console with universal hole pattern system. Suitable for DIN-L and DIN-R. Slide channel with integrated, electromechanical hold-open unit, 24 V DC, tested according to EN 1155. Hold-open position (80°–140°) and release force can be adjusted. One-piece cover, 30 mm installation height. General building approval by DIBt, Berlin for use in hold-open systems. Acceptance test required.

Color

- Silver colored similar to RAL 9006 (P 600)
- White similar to RAL 9016 (P 100)
- White similar to RAL 9010 (P 210)
- Black similar to RAL 9005 (P 190)
- Stainless steel design
- Gold (P 750)
- Other colors

TS 98 XEA EMR

Slide channel door closer according to EN 1154, with CE mark, in XEA design, including rapidly decreasing opening torque for easy door opening according to DIN SPEC 1104. Installation types: Normal installation on the pull and push side. Closing speed, 2. 15°–0° closing range, latching speed (SoftFlow), hydraulically controlled opening dampening and delayed closing can be comfortably adjusted from the front via a valve. EN 1–6 closing force can be configured from the front using a cordless screwdriver, includes visual closing force indicator. Installation console with universal hole pattern system. Suitable for DIN-L and DIN-R. 3Slide channel with integrated smoke detector with operation and maintenance indicator and electromechanical hold-open unit, 24 V DC, tested according to EN 1155 and EN 14637. Hold-open position (80°–120° / 80°–140°) and release force can be variably adjusted. Connectors available for additional detectors, an external manual trigger, and potential-free alarm contact. One-piece cover, 30 mm installation height.

Color

- Silver colored similar to RAL 9006 (P 600)
- White similar to RAL 9016 (P 100)
- White similar to RAL 9010 (P 210)
- Black similar to RAL 9005 (P 190)
- Stainless steel design
- Gold (P 750)
- Other colors

Specification texts

Smoke detector and Smoke detector

RMZ XEA

Smoke detector in XEA design, with operation and maintenance indicator, integrated power supply, and visual smoke detector for transom installation. For controlling dormakaba hold-open devices. Connectors available for additional detectors, an external manual trigger, and potential-free alarm contact. Changeable to manual reset. One-piece cover, 30 mm installation height. General building approval by DIBt, Berlin as a hold-open system. Acceptance test required. Tested according to EN 14637.

Color

- Silver colored similar to RAL 9006 (P 600)
- White similar to RAL 9016 (P 100)
- White similar to RAL 9010 (P 210)
- Stainless steel design
- Gold (P 750)
- Other colors

RM-N

Optical smoke detector, 24 V DC, for ceiling installation. Usable as a second and third detector in all dormakaba hold-open systems. With potential-free changeover contact. General building approval by DIBt, Berlin; and by VdS, Cologne, tested according to EN 54, part 7. Acceptance test required.

Color

- White similar to RAL 9003

Specification texts

2-leaf doors

TS 98 XEA GSR

Slide channel door closer according to EN 1154, with CE mark, in XEA design, including rapidly decreasing opening torque for easy door opening according to DIN SPEC 1104. Installation type: Normal installation, pull side. Closing speed, 2. 15°–0° closing range, latching speed (SoftFlow), hydraulically controlled opening dampening and closing delay can be comfortably adjusted from the front via a valve. EN 1–6 closing force can be configured from the front using a cordless screwdriver, includes visual closing force indicator. Installation console with universal hole pattern system. Suitable for DIN-L and DIN-R. Slide channel with integrated, mechanical closing sequence control, tested according to EN 1158. Closing sequence is controlled via a thrust-rod clamping system, which is independent of the door closer hydraulic system, with overload protection and continuous cover, installation height 30 mm. Suitable for DIN-L and DIN-R. General building approval by DIBt, Berlin, in conjunction with fire and smoke control doors.

Color

- Silver colored similar to RAL 9006 (P 600)
- White similar to RAL 9016 (P 100)
- White similar to RAL 9010 (P 210)
- Black similar to RAL 9005 (P 190)
- Stainless steel design
- Gold (P 750)
- Other colors

TS 98 XEA GSR EMF

Slide channel door closer according to EN 1154, with CE mark, in XEA design, including rapidly decreasing opening torque for easy door opening according to DIN SPEC 1104. Installation types: Door leaf installation, pull side Closing speed, 2. 15°–0° closing range, latching speed (SoftFlow), hydraulically controlled opening dampening and closing delay can be comfortably adjusted from the front via a valve. EN 1–6 closing force can be configured from the front using a cordless screwdriver, includes visual closing force indicator. Installation console with universal hole pattern system. Suitable for DIN-L and DIN-R. Slide channel with integrated, mechanical closing sequence control, tested according to EN 1158. Electromechanical hold-open unit, 24 V DC, tested according to EN 1155. Hold-open position (80°–130°) and release force can be adjusted. Closing sequence is controlled via a thrust-rod clamping system, which is independent of the door closer hydraulic system, with overload protection and continuous cover, installation height 30 mm. Suitable for DIN-L and DIN-R. General building approval by DIBt, Berlin for use in hold-open systems. Acceptance test required.

Color

- Silver colored similar to RAL 9006 (P 600)
- White similar to RAL 9016 (P 100)
- White similar to RAL 9010 (P 210)
- Black similar to RAL 9005 (P 190)
- Stainless steel design
- Gold (P 750)
- Other colors

TS 98 XEA GSR EMR

Slide channel door closer according to EN 1154, with CE mark, in XEA design, including rapidly decreasing opening torque for easy door opening according to DIN SPEC 1104. Installation types: Door leaf installation, pull side Closing speed, 2. 15°–0° closing range, latching speed (SoftFlow), hydraulically controlled opening dampening and delayed closing can be comfortably adjusted from the front via a valve. EN 1–6 closing force can be configured from the front using a cordless screwdriver, includes visual closing force indicator. Installation console with universal hole pattern system. Suitable for DIN-L and DIN-R. Smoke detector with operation and maintenance display integrated flush in the closing sequence control's housing. Connectors available for additional detectors, an external manual trigger, and potential-free alarm contact. Connection voltage 230 V AC, operating voltage 24 V DC. Slide channel with integrated, mechanical closing sequence control, tested according to EN 1158. Electromechanical hold-open unit, 24 V DC, tested according to EN 1155 and EN 14637. Hold-open position (80°–130°) and release force can be adjusted. Closing sequence is controlled via a thrust-rod clamping system, which is independent of the door closer hydraulic system, with overload protection and continuous cover, installation height 30 mm. Suitable for DIN-L and DIN-R. General building approval by DIBt, Berlin as a hold-open system. Acceptance test required.

Color

- Silver colored similar to RAL 9006 (P 600)
- White similar to RAL 9016 (P 100)
- White similar to RAL 9010 (P 210)
- Black similar to RAL 9005 (P 190)
- Stainless steel design
- Gold (P 750)
- Other colors

TS 98 XEA GSR BG

Slide channel door closer according to EN 1154, with CE mark, in XEA design, including rapidly decreasing opening torque for easy door opening according to DIN SPEC 1104. Installation types: Normal installation, push side. Closing speed, 2. 15°–0° doorway, latching speed (SoftFlow), hydraulically controlled opening dampening and delayed closing can be comfortably adjusted from the front via a valve. EN 1–6 closing force can be configured from the front using a cordless screwdriver, includes visual closing force indicator. Installation console with universal hole pattern system. Suitable for DIN-L and DIN-R. Slide channel with integrated, mechanical closing sequence control, tested according to EN 1158. Closing sequence is controlled via a thrust-rod clamping system, which is independent of the door closer hydraulic system, with overload protection and continuous cover, installation height 30 mm. Suitable for DIN-L and DIN-R. General building approval by DIBt, Berlin, in conjunction with fire and smoke control doors.

Color

- Silver colored similar to RAL 9006 (P 600)
- White similar to RAL 9016 (P 100)
- White similar to RAL 9010 (P 210)
- Black similar to RAL 9005 (P 190)
- Stainless steel design
- Gold (P 750)
- Other colors

TS 98 XEA GSR EMF 2 BG

Slide channel door closer according to EN 1154, with CE mark, in XEA design, including rapidly decreasing opening torque for easy door opening according to DIN SPEC 1104. Installation types: Normal installation, push side. Closing speed, 2. 15°–0° doorway, latching speed (SoftFlow), hydraulically controlled opening dampening and delayed closing can be comfortably adjusted from the front via a valve. EN 1–6 closing force can be configured from the front using a cordless screwdriver, includes visual closing force indicator. Installation console with universal hole pattern system. Suitable for DIN-L and DIN-R. Slide channel with integrated, mechanical closing sequence control, tested according to EN 1158.

Electromechanical hold-open unit in active and inactive leaf, 24 V DC, tested according to EN 1155. Hold-open position (80°–120°) and release force can be adjusted. Closing sequence is controlled via a thrust-rod clamping system, which is independent of the door closer hydraulic system, with overload protection and continuous cover, installation height 30 mm. Suitable for DIN-L and DIN-R. General building approval by DIBt, Berlin for use in hold-open systems. Acceptance test required.

Color

- Silver colored similar to RAL 9006 (P 600)
- White similar to RAL 9016 (P 100)
- White similar to RAL 9010 (P 210)
- Black similar to RAL 9005 (P 190)
- Stainless steel design
- Gold (P 750)
- Other colors

TS 98 XEA GSR EMR 2 BG

Slide channel door closer according to EN 1154, with CE mark, in XEA design, including rapidly decreasing opening torque for easy door opening according to DIN SPEC 1104. Installation types: Normal installation, push side. Closing speed, 2. 15°–0° doorway, latching speed (SoftFlow), hydraulically controlled opening dampening and delayed closing can be comfortably adjusted from the front via a valve. EN 1–6 closing force can be configured from the front using a cordless screwdriver, includes visual closing force indicator. Installation console with universal hole pattern system. Suitable for DIN-L and DIN-R. Smoke detector with operation and maintenance display integrated flush in the closing sequence control's housing. Connectors available for additional detectors, an external manual trigger, and potential-free alarm contact. Connection voltage 230 V AC, operating voltage 24 V DC. Slide channel with integrated, mechanical closing sequence control, tested according to EN 1158.

Electromechanical hold-open device in active and inactive leaf, 24 V DC, tested according to EN 1155 and EN 14637. Hold-open position (80°–120°) and release force can be adjusted. Closing sequence is controlled via a thrust-rod clamping system, which is independent of the door closer hydraulic system, with overload protection and continuous cover, installation height 30 mm. Suitable for DIN-L and DIN-R. General building approval by DIBt, Berlin as a hold-open system. Acceptance test required.

Color

- Silver colored similar to RAL 9006 (P 600)
- White similar to RAL 9016 (P 100)
- White similar to RAL 9010 (P 210)
- Black similar to RAL 9005 (P 190)
- Stainless steel design
- Gold (P 750)
- Other colors

Regulations/information

Hold-open devices

The use of hold-open devices is subject to special regulations due to official approval requirements. They particularly concern acceptance, ongoing monitoring and maintenance.

This information will inform all parties involved regarding the most important measures in operating hold-open devices as set forth in official regulations.

Please refer to the following documents for additional information:

- Richtlinien für Feststellanlagen des Deutschen Instituts für Bautechnik, Berlin [The German Institute for Structural Engineering's guidelines for hold-open systems]
- Allgemein bauaufsichtliche Zulassung der jeweiligen Feststellanlage [General building approval for the respective hold-open system]
- EN 1155
- EN 14637
- DIN 14677

1. General

1.1 In closures that are held open by a hold-open system, the required space for closing must be kept clear at all times. This area must be clearly marked with a label, floor markings or similar. If necessary, constructive measures must be employed to ensure that lines, stored goods or components (e.g. suspended ceilings or their components) do not fall into the area that must be kept clear.

1.2 Smoke detectors should be used for hold-open devices to the extent possible. Smoke detectors must be used for hold-open devices for closures in emergency routes.

1.3 Every hold-open device must also have a manual triggering capability without affecting the operational capability of the release mechanism. In door closers with an electromagnetic hold-open unit, it can be overridden by applying slight pressure on the door leaf. If magnetic clamps or free-swinging door closers are used, triggering is done via a button. The manual release used for this must be read and bear the letters "close door". The button must be in the vicinity of the closure and may not be concealed by the held-open closure.

2. Acceptance test

2.1 After ready-to-use installation at the place of use, proper function and correct installation should be ascertained via an acceptance test. The acceptance test may only be carried out by the manufacturer's professionals in monitoring systems and/or hold-open devices, by these authorized professionals or a test center designated for that purpose.

2.2 After the acceptance test has been carried out, an approval plate (105 x 52 mm) must be permanently affixed on the wall directly near the closure with the inscription:

Hold-open system

Approved by

(Company signature, name and year of acceptance)

2.3 A certificate of successful acceptance testing must be issued to the operator, and the same must store it.

3. Periodic monitoring

3.1 This hold-open system must continuously be kept in an operational state and must be checked at least once per month for proper functionality.

3.2 Furthermore, the operator is obliged to test or have testing performed on proper and error-free interoperation of all devices along with maintenance, unless a shorter time period is specified in the approval notice. This testing and maintenance may only be carried out by a professional or person trained for this.

3.3 The scope, result, and time of periodic monitoring must be recorded, and these recordings must be stored by the operator.

